

WAX CATALOGUE

2020 - 2021



VOLA 
RACING



FLY TO SUCCESS

— 85 — YEARS OF STORIES & PODIUMS

Depuis 1935 nous concevons des farts pour apporter de meilleurs sensations et de meilleures performances à chacun. Chaque fart est conçu, fabriqué et emballé en France, au pied du Mont-Blanc à Passy. La passion du ski et l'innovation sont des valeurs motrices, transmettent de générations en générations dans l'entreprise.

Since 1935 we have been created farts to bring better sensations and better performances to everyone. Each wax is designed, cast and packed in France, at the foot of the Mont Blanc in Passy. The passion of skiing and the innovation are our values that we are transferring from generation to generation in the company.

ADVICE ————— Pages 04-13

WAX ————— Pages 14-41

ACCESSORIES ————— Pages 42-61

EQUIPMENT ————— Other side
of the catalogue ↻



#volaracing





ADVICE



VOLA Advice

WAXING SELECTOR & VIDEOS TUTORIALS



Easy To Use



Helpfull



100% Fun

Download the App !



CHOOSE YOUR WAX

	E-Wax	MyEcoWax	Universal Wax	Bases Wax	Race Wax	Top Finish Wax	Kick Wax & Klusters Wax
<i>Holiday</i> HOBBY	[Bar]						[Bar]
<i>Weekly</i> HOBBY	[Bar]						[Bar]
<i>Expert</i> HOBBY & TRAINING	[Bar]						[Bar]
<i>Junior</i> RACER	[Bar]						[Bar]
<i>Senior</i> RACER	[Bar]						[Bar]

FREE FLUOR RANGES

Universal Wax



E-Wax



Race Wax - MX

MyEcoWax



No Fluor
APPROVED

AIR °C

× 6 ×

GLIDE WAX

	All Snows	Fresh Snow		Old & Transformed Snow	
		Dry	Wet	Dry	Wet
All T°	E-Wax Universal Wax Bases Wax : Touring Graphite LF Graphite MX901 X-Hard Hard Medium Soft			Base VRB	
Cold	MX Bleu MyEcoWax Ocean	LF Bleu	HF Bleu	LF Bleu Moly	HF Bleu Moly
Moderate	MX Violet MyEcoWax Lavender	LF Violet	HF Violet	LF Violet Moly	HF Violet Moly
Intermediate	MX Rouge MyEcoWax Ruby	LF Rouge	HF Rouge	LF Rouge Moly	HF Rouge Moly
Warm	MX Jaune MyEcoWax Sun	LF Jaune	HF Jaune	LF Jaune Moly	HF Jaune Moly

TOP FINISH

	All Snows	Fresh Snow	Transformed Snow
Cold	LL15 BLEU	Propulseur Bleu FD300	Propulseur Bleu Moly FD300 FD300A
Moderate	LL15 VIOLET	FD4	FD4
Intermediate	LL15 ROUGE	FD301N	FD301 T2625+
Warm	LL15 JAUNE	Propulseur Jaune FD302	Propulseur Jaune Moly FD302

GRIP WAX

	Fresh Snow	Old Snow	Frozen Snow	Wet Snow
All T°	P44 GRIP			
Very cold	P43 GRIP		K43	
Cold	P40 GRIP	P45 GRIP	K40	K40
Moderate	P41 GRIP	P46 GRIP	K41	K41
Intermediate	P42 GRIP			K42
0°			ZÉRO DEGRÉ LF	ZÉRO DEGRÉ LF K44

THE WAX MADE IN FRANCE SINCE 1935

× 7 ×



WORK
RACE
WIN
REPEAT

VOLA
RACING

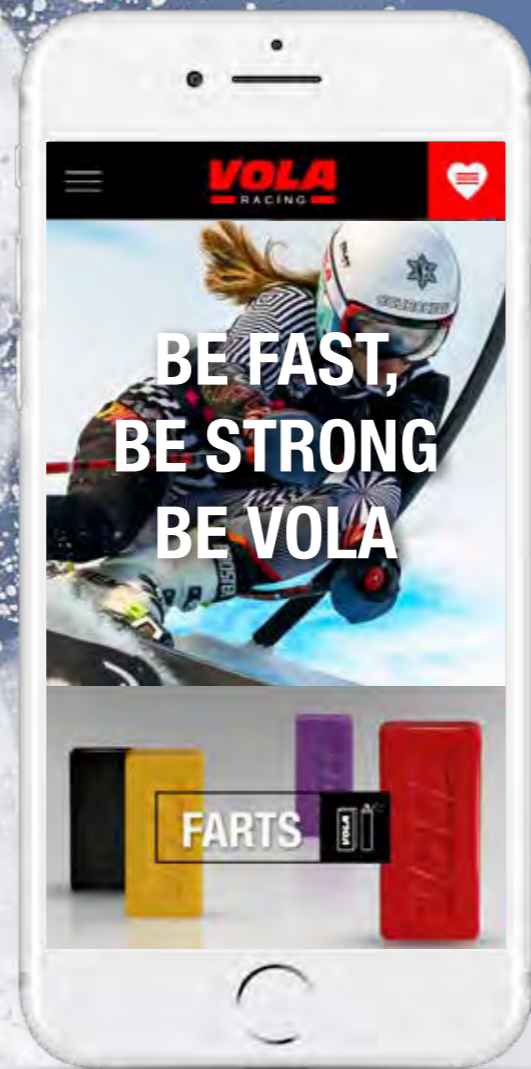

LET'S EXPLORE OUR WEBSITE

vola.fr

MOLYBDEN WAX



Le molybdène est un composé chimique avec des propriétés hydrophobes très intéressantes sur certains types de neige comme les neiges dites anciennes (avec des cristaux de neige érodés). Les additifs au molybdène placés dans les farts VOLA offrent de très bonnes performances dans les conditions de neige à grains transformés avec un fort coefficient de friction (neiges artificielles, gros sel, gelées, sales). Sa consistance grasse lui procure un fort pouvoir de lubrification tout en permettant de repousser la saleté et la pollution. Nécessite l'utilisation de la brosse acier ultra fin (fine steel) après raclage.



Molybden is a chemical compound with hydrophobic properties very interesting on certain types of snow like old snow (with snow crystals eroded). The molybden additives placed in VOLA waxes offer very good performance in snow conditions with transformed snow which has a high coefficient of friction (artificial snow, frozen, dirty). His greasy consistency gives him a strong lubricity while allowing repel dirt and pollution. Requires the use of ultra fine steel brush (fine steel) after scraping.



Molybdän ist eine chemische Verbindung mit hydrophoben Eigenschaften sehr interessant für bestimmte Arten von Schnee wie das alte Sprichwort Schnee (mit Schneekristallen abgetragen). Die Molybdän-Zusätze in Wachsen VOLA platziert bieten sehr gute Leistung bei Schnee mit einem hohen Reibungskoeffizienten (künstliche Schnee, Salz, gefroren, schmutzig) Körner umgewandelt. Seine fettige Konsistenz gibt ihm eine starke Schmierfähigkeit und ermöglicht weisen Schmutz und Umweltverschmutzung. Erfordert die Verwendung von ultrafeinen Stahlbürste (Feinstahl) nach dem Abkratzen.



Il molibdeno è un composto chimico con proprietà idrofobiche molto interessanti su alcuni tipi di neve, come la neve vecchia dicendo (con cristalli di neve erosi). Gli additivi molibdeno collocati nelle cere VOLA offrono ottime prestazioni in condizioni di neve trasformata con un alto coefficiente di attrito (neve artificiale, sale, congelati, sporchi) chicchi. La sua consistenza grassa gli dà un forte potere lubrificante, consentendo respingere lo sporco e l'inquinamento. Richiede l'uso di spazzole in acciaio ultra fine (acciaio fine) dopo la raschiatura.

GRAPHITE WAX



Les farts graphites sont destinés aux semelles graphitées. Toutes les semelles de ski de couleur noire sont graphitées. Ces semelles, après plusieurs utilisations, perdent leur charge en graphite et donc la capacité hydrophobique est diminuée. Faire un fartage avec un fart graphite va alors recharger la semelle. Ces farts sont à utiliser tous les 7 à 10 fartages pour recharger une semelle. Les bases graphitées sont utilisées régulièrement grâce au pouvoir lubrifiant du graphite sur des neiges spécifiques.



Graphite waxes are for graphitized bases. All ski bases black are graphitized. These bases, after several uses, lose their charge in graphite and therefore the hydrophobic capacity is diminished. Make a waxing with a graphite wax will reload the base. These waxes are used every 7-10 waxing to recharge the base. The graphite bases are used regularly thanks to the lubricity of graphite on specific snow.



Graphit-Wachse sind für Sohlen graphitierter. Alle Ski-Sohlen sind schwarz graphitiert. Diese Einlegesohlen, nach mehreren Anwendungen, verlieren ihre Ladung in Graphit und damit die hydrophoben Kapazität verringert wird. Machen Sie ein Wachs mit einem Wachs Graphit dann laden Sie die Sohle. Diese Wachse werden alle 7-10 Wachsen um die Sohle wieder aufladen. Die graphitierten Basen werden regelmäßig durch die Schmierfähigkeit des Graphits auf bestimmte Schnee verwendet.



Gli oliine grafite sono per soles grafitato. Tutte le solette nero sono grafitato. Queste soles, dopo vari utilizzi, perdono la loro carica in grafite e quindi la capacità idrofobo è diminuita. Fare una cera con grafite cera quindi ricaricare la suola. Queste cere vengono utilizzati ogni 7-10 ceretta per ricaricare la suola. Le basi di grafite vengono utilizzati regolarmente attraverso il potere lubrificante della grafite sulla neve specifico.

HOW TO WAX FOR TRAINING

U12



U14



PRO



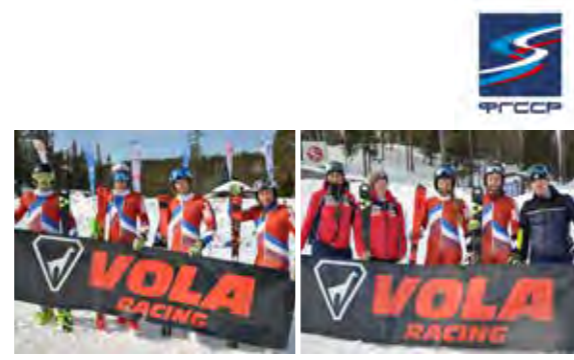

A story

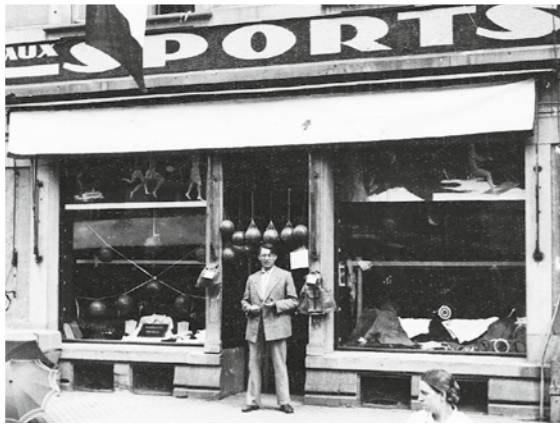

Où tout à commencé: le magasin de sports à Colmar en 1935
Where it all started: the sports store in Colmar in 1935



Une passion du ski qui se transmet de génération en génération
A passion for skiing transmitted from generation to generation



Une production artisanale et Française depuis toujours
An artisanal and French production since always



L'entreprise quitte Colmar et s'installe à Passy, en Haute-Savoie
The company leaves Colmar and settles in Passy, in Haute-Savoie



Travailler au pied du Mont-Blanc, ça n'a pas de prix !
Working at the foot of Mont-Blanc is priceless !

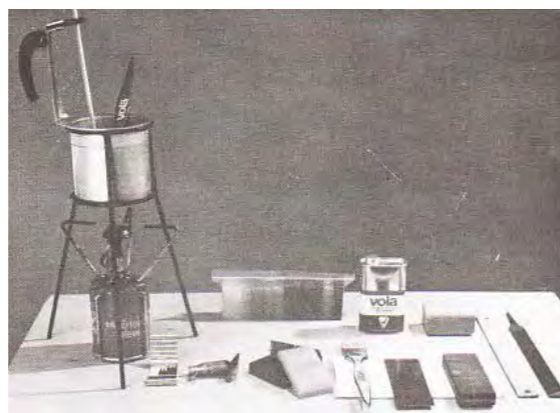

Le «shooting» du premier livret technique
The «shooting» of the first technical booklet



Tests de fartage avec les plus grands skieurs tel que A. Duvillard
Waxing tests with famous skiers like A. Duvillard



Une ambiance conviviale
A friendly atmosphere



Des produits qui ne cessent d'innover
Products that keep innovating



An international vision:
Vola at the Winter Park slalom, Colorado



Toujours avec le plaisir de transmettre notre savoir-faire
Always with the pleasure of transmitting our know-how



Vola a participé au salon ISPO depuis le début
Vola has participated in ISPO since the beginning



1988 / Tests de glisse au Tour à Chamonix
1988 / Gliding tests at the Tour in Chamonix



Démonstration de fartage et d'affûtage en mai 1989
Waxing and sharpening demonstration, May 1989





WAX

Top Finish Wax
Pages 16-17



Race Wax
Pages 18-27

MX NO FLUOR



No Fluor
APPROVED

LF LOW FLUOR



HF HIGH FLUOR



MOLY



Bases Wax
Pages 28-31



Universal Wax
Pages 32-33



No Fluor
APPROVED

MyEcoWax
Pages 34-35



FREE FLUOR

E-Wax
Pages 36-37



FREE FLUOR

Grip Wax
Pages 38-39



Remover Wax
Pages 40-41





Top Finish WAX

LL15 Accelerators 75ml **NEW** Formula

Inspiré de notre recherche sur les farts liquides, cette association de composés hydrophobes est conditionnée sous forme d'aérosol. Cet accélérateur est à projeter sur la semelle du ski, puis, laisser sécher puis brosser à la brosse nylon soft ou à la feutrine fournie avec le LL15.

Made from our research on liquid waxes, this mix of hydrophobic compounds is packed in aerosol. This accelerator has to be sprayed on the ski base; Let it dry, then brush with nylon soft brush or a felt pad supplied with the LL15.

Gemacht von unserer Forschung an Flüssigwachs, wird diese Mischung von hydrophoben Verbindungen in Aerosol verpackt. Sprühen Sie das Wachs; Lassen Sie es trocknen und Pinsel kaum mit Nylonsoftbürste oder Wollfilzbürste wird mit dem LL15 geliefert.

Risultato della nostra continua ricerca nell'ambito delle scioline liquide, questo mix di componenti idrofobici è confezionato in aerosol. Questo acceleratore va applicato direttamente sulla soletta, una volta asciutto va spazzolato e lucidato con l'apposito accessorio fornito con LL15.

- Blue**
REF. 240901
-25°C < -10°C
- Purple**
REF. 240902
-12°C < -4°C
- Red**
REF. 240903
-5°C < 0°C
- Yellow**
REF. 240904
-2°C < 10°C



× 16 ×

NEW Clean FORMULA



FD300C
30g REF. 240811
10g REF. 240801

Snow Temperature: -8°C / -18°C
Air Humidity: 30% / 70%
Grain Snow: Fresh / Old / Transformed



FD4C
30g REF. 240812
10g REF. 240802

Snow Temperature: -6°C / -12°C
Air Humidity: 60% / 100%
Grain Snow: All kind of snow



FD301C
30g REF. 240813
10g REF. 240803

Snow Temperature: -3°C / -9°C
Air Humidity: 60% / 100%
Grain Snow: Old / Icy / Transformed



FD302C
30g REF. 240814
10g REF. 240804

Snow Temperature: -4°C / +2°C
Air Humidity: 60% / 90%
Grain Snow: Fresh / Old / Artificial



FD300AC
30g REF. 240810

Snow Temperature: -8°C / -18°C
Air Humidity: 30% / 70%
Grain Snow: Artificial

Spécial neiges froides et artificielles.
Special cold and artificial snow.
Sonder Kälte und Kunstschnee.
Speciale neve fredda e artificiale.



T2625+C
30g REF. 240816

Snow Temperature: -4°C / -12°C
Air Humidity: 40% / 80%
Grain Snow: Old

Spécial neiges froides vieilles.
Special old cold snow.
Spezieller alter kalter Schnee.
Speciale vecchia neve fredda.



FD301NC
30g REF. 240815

Snow Temperature: -3°C / -7°C
Air Humidity: 50% / 90%
Grain Snow: New / Fresh / Snowfall

Spécial neiges fraîches et/ou tombantes.
Special fresh and/or falling snow.
Spezieller frischer und/oder fallender Schnee.
Speciale neve fresca e/o caduta.

Accelerator blocks 15g

Pain de 15g hautement fluoré. Formule pour les neiges fraîches. Contient un additif au molybdène pour les neiges vieilles et artificielles. A crayonner légèrement puis polir avec un liège ou une feutrine. Enfin brosser avec une brosse crin de cheval (012010). Bleu pour les neiges froides; jaune pour les neiges chaudes.

15g Block High Fluor. Composition developed for fresh snow. Contains molybdene additives for old and artificial snow. Rub on slightly and then polish with a pad or a cork. Then brush out with a horsehair brush (012010). Blue for cold snow; yellow for warm, humid snow.

Blockform mit Hochfluorgehalt 15g. Dieses Wachs zeigt bei frisch gefallenem Naturschnee unschlagbare Werte. Hochfluoriertes Race Wachs mit Molybdän-Anteil. Leicht aufreiben, dann mit einem Kork oder einem Wollfilz einpolieren. Schließlich mit einer Pferdehaar borste (012010) bürsten. Blau für kalten Schnee; gelb für warmen Schnee.

Blocco da 15g altamente fluorato. Formula speciale per la neve fresca. Contiene un aggiuntivo al molibdeno per la neve vecchia e artificiale. Sfregare leggermente e lucidare con un feltro o un sughero. Infine spazzolare con una spazzola in crine di cavallo (012010). Blu per le nevi fredde; gialla per le nevi calde.

- New Snow Cold**
REF. 224000
-12°C > -5°C
- New Snow Warm**
REF. 224001
-5°C > 0°C
- Old Snow Cold**
REF. 224012
-12°C > -5°C
- Old Snow Warm**
REF. 224013
-5°C > 0°C



HCF 30ml REF. 224708

Huile universelle à appliquer sur les chants des skis de vitesse à l'aide d'un chiffon. Ne pas appliquer sur la semelle.

Universal Sidewall oil for speed events. This oil should only be used on the sidewall, do not apply it on the base.

Schmiermittel für die Kanten, daher nicht auf den Skibelag auftragen. Ölio universale per le lamine. Da non mettere sulla soletta. Utilizzare un straccio per l'applicazione.





× 17 ×







Race WAX

 La gamme Race Wax est issue de la recherche et des tests menés par VOLA pour obtenir la meilleure glisse possible de vos skis. Les produits allient la résistance et la longévité d'un fart de base tout en possédant un additif fluoré pour en faire un fart de course sensationnel. Les farts VOLA fluorés sont des farts de compétition légèrement fluorés (LF) ou à forte teneur en fluor (HF) en fonction du taux d'hygrométrie. Le fluor (Polytétrafluoroéthylène) est un produit hydrophobe permettant une forte accélération. Le fluor est un polymère qui se distingue par un coefficient de frottement extrêmement faible apportant une qualité de glisse accrue aux skis. Les farts sont déclinés sous plusieurs plages de températures pour une plus grande efficacité.

 The range Race Wax is made from research and tests conducted by VOLA to get the best possible glide of your skis. These products combine resistance and durability of a base wax while having a fluorinated additive to make a sensational race wax. VOLA fluor waxes are high competition wax slightly fluorinated (LF) or highly fluorinated (HF) depending to the hygrometry. The fluor (Polytetrafluoroethylene) is an hydrophobic product which allows a fast acceleration. The fluor is a polymer which is characterized by one of the lowest coefficients of friction against any solid. This specification brings an important improvement of the quality of the glide. The range has been declined in three colors corresponding to the air temperature to offer very efficient products.

 Die Reihe Race Wax ist aus Forschung und Tests von VOLA durchgeführt, um die bestmögliche Gleiten der Ski bekommen. Produkte kombinieren Beständigkeit und Langlebigkeit eines Wachs-Basis, während mit einer fluorierten Additiv ein perfekt Rennen Wachs machen. Es gibt hochfluorierte Wachs (HF) und leichtfluorierte Wachs (LF). Das Fluor (Polytetrafluoroethylene) ist ein wasserscheues Produkt, das das Wasser zurückdrängt. Fluor ist ein Polymer, das durch eine extrem niedrige gekennzeichnet ist, eine verbesserte Qualität der Ski Gleitreibung. Es ist für alle Schneearten im angegebenen Temperaturbereich geeignet.

 La gamma Race Wax è fatto dalla ricerca e test condotti da VOLA per ottenere la migliore velocità degli sci. Prodotti uniscono resistenza e durata di una base di cera pur avendo un additivo fluorurato per fare una cera sensazionale. La gamma delle scioline Pro è fatto per le gare. Lei è disponibili in tre colori principali il cui impiego dipende dalla temperatura dell'aria e della neve. Ci sono le scioline fluorate (LF) e le scioline altamente fluorate dipende dall'igrometria. Il fluoro è un polimero che è caratterizzata da un bassissimo fornire una migliore qualità di sci scivolanti attrito.





BLUE
-25°C > -10°C / -13°F > 10°F

MX NO FLUOR

No Fluor
APPROVED

- 60ml REF. 240501
- 250ml REF. 240701
- 80g REF. 221006
- 13x80g REF. 221006K
- 200g REF. 221100
- 500g REF. 221200
- 5kg REF. 221401
- 12kg REF. 221404



- 60ml REF. 240521
- 250ml REF. 240721
- 40g REF. 240021
- 22x40g REF. 240021K
- 80g REF. 240121
- 13x80g REF. 240121K
- 200g REF. 240221

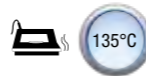

HF HIGH FLUOR

LF LOW FLUOR



- 60ml REF. 240511
- 250ml REF. 240711
- 80g REF. 240111
- 13x80g REF. 240111K
- 200g REF. 240211



MOLYBDEN
Molybden wax for old and dirty snow

- LF 100ml REF. 240631
- HF 100ml REF. 240641
- LF 80g REF. 240131
- HF 80g REF. 240141



MOLY

×20×

×21×



PURPLE

-12°C > -4°C / 10°F > 25°F

MX NO FLUOR

No Fluor
APPROVED

- 60ml REF. 240502
- 250ml REF. 240702
- 80g REF. 221009
- 13x80g REF. 221009K
- 200g REF. 221103
- 500g REF. 221209
- 5kg REF. 221407
- 12kg REF. 221408



- 60ml REF. 240522
- 250ml REF. 240722
- 40g REF. 240022
- 22x40g REF. 240022K
- 80g REF. 240122
- 13x80g REF. 240122K
- 200g REF. 240222



HF HIGH FLUOR

LF LOW FLUOR



- 60ml REF. 240512
- 250ml REF. 240712
- 80g REF. 240112
- 13x80g REF. 240112K
- 200g REF. 240212

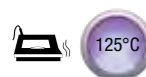

MOLYBDEN
Molybden wax for
old and dirty snow

- LF 100ml REF. 240632
- HF 100ml REF. 240642
- LF 80g REF. 240132
- HF 80g REF. 240142

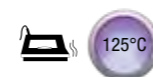

MOLY



RED
-5°C > 0°C / 23°F > 32°F

MX NO FLUOR

No Fluor
APPROVED

- 60ml REF. 240503
- 250ml REF. 240703
- 80g REF. 221007
- 13x80g REF. 221007K
- 200g REF. 221101
- 500g REF. 221201
- 5kg REF. 221402
- 12kg REF. 221405



- 60ml REF. 240523
- 250ml REF. 240723
- 40g REF. 240023
- 22x40g REF. 240023K
- 80g REF. 240123
- 13x80g REF. 240123K
- 200g REF. 240223

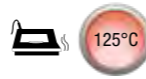

HF HIGH FLUOR

LF LOW FLUOR



- 60ml REF. 240513
- 250ml REF. 240713
- 80g REF. 240113
- 13x80g REF. 240113K
- 200g REF. 240213



MOLYBDEN
Molybden wax for old and dirty snow

- LF 100ml REF. 240633
- HF 100ml REF. 240643
- LF 80g REF. 240133
- HF 80g REF. 240143





YELLOW

-2°C > 10°C / 28°F > 50°F

MX NO FLUOR

No Fluor
APPROVED

- 60ml REF. 240504
- 250ml REF. 240704
- 80g REF. 221008
- 13x80g REF. 221008K
- 200g REF. 221102
- 500g REF. 221202
- 5kg REF. 221403
- 12kg REF. 221406

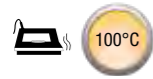

- 60ml REF. 240524
- 250ml REF. 240724
- 40g REF. 240024
- 22x40g REF. 240024K
- 80g REF. 240124
- 13x80g REF. 240124K
- 200g REF. 240224

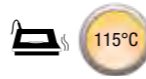

HF HIGH FLUOR

LF LOW FLUOR



- 60ml REF. 240514
- 250ml REF. 240714
- 80g REF. 240114
- 13x80g REF. 240114K
- 200g REF. 240214



MOLYBDEN
Molybden wax for
old and dirty snow

- LF 100ml REF. 240634
- HF 100ml REF. 240644
- LF 80g REF. 240134
- HF 80g REF. 240144







Bases WAX

- 

Les Bases Wax sont des farts développés pour les compétiteurs. Grâce à 3 niveaux de dureté, soft/medium/hard, et différentes spécificités (graphite, fluoré ou non, etc...) ces farts répondent à tous les besoins: protection ou imprégnation de la semelle, performances sur des neiges chaudes, froides, sèches et/ou anciennes. Cette gamme de farts de pointe, riche et variée, permet de cibler le produit nécessaire suivant la pratique (alpin, nordique, randonnée, saut à ski, courses ou entraînement) pour préparer son matériel de façon optimale.
- 

Wax Bases are waxes developed for competitors. Thanks to 3 levels of hardness, soft / medium / hard, and different specificities (graphite, fluorinated or not...) these waxes answer all the needs: protection or impregnation of the ski base, performances on warm, cold, dry snow and / or old snow. This range of advanced waxes makes it possible to target the necessary product according to the practice (alpine, nordic, touring, ski jumping, races or training) to prepare its equipment in an optimal way.
- 

Wax Bases sind Wachse, die für den Wettkampf entwickelt wurden. Dank 3 Härtegraden, weich / mittel / hart, und verschiedenen Spezifitäten (Graphit, Fluorid, etc ...) erfüllen diese Wachse alle Bedürfnisse: Schutz und Imprägnierung des Belags, Leistungen auf heißem, kaltem, trockenem, neuem oder altem Schnee. Diese Reihe von high-end Wachsen, ist reich an Vielfältigkeit und ermöglicht, das benötigte Schneesportgerät entsprechend der Praxis (Alpin, Nordisch, Skitouring, Skispringen, uvm.) optimal vorzubereiten um eine maximale Performance zu erzielen.
- 

Le scioline base sono scioline sviluppate per gli atleti. Grazie a 3 livelli di durezza, morbida / media / dura e diverse specificità (grafite, fluoro o no, ecc ...) queste scioline rispondono a tutte le esigenze: protezione o impregnazione della suola, prestazioni su neve calda, fredda, asciutta e / o vecchia. Questa gamma di scioline avanzate, ricca e varia, consente di avere il prodotto necessario a seconda la pratica (alpino, nordico, escursione, salto con gli sci, gare o allenamento) per preparare la propria attrezzatura in modo ottimale.

No Fluor
APPROVED

Ski Touring Base

Fart Spécial Rando de compétition. Fart développé pour les passionnés de ski de randonnée recherchant la performance. De subtils mélanges ont permis à VOLLA de développer un fart à chaud n'empêchant pas les peaux de phoque d'adhérer à la semelle. Pour les habitués, il peut également être crayonné sur les peaux en tant qu'anti-botte même si certains spécialistes préféreront mettre un fart liquide pour une utilisation plus facile.

Special ski touring wax. Wax developed for ski touring performance. Subtle blends allowed VOLLA to develop a solid wax which is ideal for skins (the skins continue to stick to the base). For regulars, it can be rub on the skins as an anti-balling snow plate even if some experts prefer to put liquid for an easier use.

Sonder Skitouren Wachs. Wachs entwickelt für Enthusiasten auf der Suche für Skitouren Leistung. Subtile Mischungen erlaubt VOLLA entwickeln eine hot-Wachs, das ideal für Skins ist (dass die Felle an der Sohle haften.). Für Stammkunden, kann es auch auf der Haut als Anti-Boot-Bleistift werden, obwohl einige Experten lieber ein flüssiges Wachs für eine einfachere Nutzung setzen.

Sciolina speciale sci alpinismo. Sciolina sviluppato per gli appassionati che cercano prestazioni di sci alpinismo. Miscela sottile permesso VOLLA sviluppare una sciolina che è ideale per le pelli. (non impedisce le bucce aderire alla suola.) Per abituali, può anche essere a matita sulla pelle come un anti-boot anche se alcuni esperti preferiscono mettere una cera liquida per uso più facile.

- 60ml REF. 224505 **NEW**
- 75ml REF. 224504
- 80g REF. 224502
- 200g REF. 224503 **NEW**
- 500g REF. 224501



Ski Jumping Base

Keramic
200g REF. 225060

Fart spécial Ceramic pour saut à skis sur tremplins synthétiques.

Special Ceramic wax for Ski Jumping.
Special Ceramic Wachs für Skispringen.
Sciolina speciale Ceramic per il salto a sci.

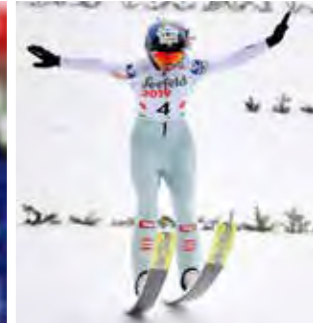

© LIFE SPORT PRODUCTS

Special Bases



Graphite Base
200g REF. 224100

Fart graphité pour l'entretien.
Graphite wax for maintenance.
Graphitwachs für die Wartung.
Cera di grafite per manutenzione.



VRB Base
200g REF. 224101

VRB. Base graphitée destinée au géant, super géant et descente. Cette base convient très bien aux neiges très froides et sèches.
VRB graphite. For GS, Super G and Downhill on very cold and dry snow.
VRB. Graphitwachs für Riesenslalom, Super G und Downhill. Besonders geeignet für kalten und trockenen Schnee.
VRB. Base con grafite destinata al gigante, super-G e discesa. Ottimale per nevi fredde e asciutte.



LF Graphite Base
80g REF. 224136 / 200g REF. 224135

Base graphitée fluorée, à utiliser comme base antistatique.
Fluorinated graphite base, to be used as antistatic base.
Basis aus Fluor-Graphit, zur Verwendung als antistatische Unterlage.
Base in grafite fluorurata, da utilizzare come base antistatica.

Bases



Hard Base
200g REF. 224130

Base très dure non fluorée. Protège efficacement contre l'abrasion de la neige. Excellente qualité d'accélération, idéale pour les disciplines techniques.
Very hard, non-fluorinated base. Protects effectively against abrasion of snow. Excellent acceleration quality, ideal for technical disciplines.
Sehr harte, nicht fluorierte Base. Schützt effektiv vor Schneeschäden. Hervorragende Beschleunigungsqualität, ideal für technische Disziplinen.
Base molto dura, non fluorurata. Protegge efficacemente contro l'abrasione della neve. Eccellente qualità di accelerazione, ideale per le discipline tecniche.



Medium Base
80g REF. 224034 / 200g REF. 224131

Base non fluorée de dureté intermédiaire. À utiliser seule ou comme première couche avant application de farts fluorés. Recommandée pour les disciplines GS et SuperG en ski alpin. Idéale pour les courses longues distances en ski de fond.
Non-fluorinated base of intermediate hardness. To use alone or as a first layer before applying fluorinated waxes. Recommended for GS and SuperG disciplines in alpine skiing. Ideal for long distance races in cross-country skiing.
Nicht fluorierte Basis der Zwischenhärte. Vor dem Auftragen von fluorierten Wachsen allein oder als erste Schicht zu verwenden. Empfohlen für GS und SuperG Disziplinen in alpin. Ideal für long distance im Langlauf.
Base non fluorurata di durezza intermedia. Da usare da solo o come prima mano prima di applicare cera fluorurata. Consigliato per le discipline GS e SuperG in alpino. Ideale per le gare di lunga distanza nello sci di fondo.



Medium + Base
200g REF. 224132

Base fluorée de dureté intermédiaire. À utiliser seule ou comme première couche avant application de farts fluorés. Recommandée pour les disciplines GS et SuperG en ski alpin. Idéale pour les courses longues distances en ski de fond.
Fluorinated base of intermediate hardness. To use alone or as a first layer before applying fluorinated waxes. Recommended for GS and SuperG disciplines in alpine skiing. Ideal for long distance races in cross-country skiing. For very wet conditions.
Fluorierte Basis der Zwischenhärte. Vor dem Auftragen von fluorierten Wachsen allein oder als erste Schicht zu verwenden. Empfohlen für GS und SuperG Disziplinen in alpin. Ideal für long distance im Langlauf. Für sehr nasse Bedingungen.
Base fluorurata di durezza intermedia. Da usare da solo o come prima mano prima di applicare cera fluorurata. Consigliato per le discipline GS e SuperG in alpino. Ideale per le gare di lunga distanza nello sci di fondo. Per condizioni molto umide.



MX 901 Base
200g REF. 224126
500g REF. 224127

MX 901. Base polyvalente, idéale pour l'entraînement. Spécialement développé pour éviter le blanchiment des semelles. Adapté également à l'imprégnation des skis neufs avec une housse Thermojoimax.

MX 901. Training ski wax PRO. Developed to avoid the burn of the base which occurs on aggressive mad-man snows. MX901 is also made for the impregnation of new skis with a Thermojoimax.

MX 901. Training Skiwachs PRO. Es erlaubt auf aggressivem Schnee zu trainieren, da der Skibelag besser geschützt ist. Auch gemacht für Imprägnierung die Neue Rennskis mit Thermojoimax.

MX 901. Specialmente sviluppato per proteggere le solette del abrasione delle neve artificiale aggressive. Fatto per impregnare nuovi sci di competizione con un Thermojoimax.



X-Hard Base
200g REF. 224115

Special Extra Hard. Durcisseur.
Special Extra Hard. Hardener.
Special Extra Hard. Härter.
Special Extra Hard. Induritore.

× 30 ×

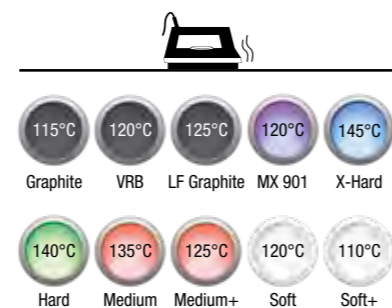

Liquid Medium Base NEW
250ml REF. 224631

Base Medium placée à l'état liquide pour une application rapide.
Medium Base placed in liquid state for quick application.
Medium Basis in flüssigem Zustand für eine schnelle Anwendung.
Base media posizionata allo stato liquido per una rapida applicazione.



Soft Base
200g REF. 224133

Base tendre non fluorée permettant d'atteindre des vitesses très élevées, recommandée pour les disciplines de vitesse.
Soft non-fluorinated base allowing to reach very high speeds, recommended for the disciplines of speed.
Soft, nicht fluorierte Basis, die es erlaubt, sehr hohe Geschwindigkeiten zu erreichen, empfohlen für die Disziplinen der Geschwindigkeit.
Base soft non fluorurata che consente di raggiungere velocità molto elevate, consigliata per le discipline di velocità.

× 31 ×



Soft + Base
200g REF. 224134

Base tendre fluorée permettant d'atteindre des vitesses très élevées, recommandée pour les disciplines de vitesse. Pour conditions très humides.
Soft fluorinated base allowing to reach very high speeds, recommended for speed disciplines. For very wet conditions.
Soft fluorierte Basis, die es erlaubt, sehr hohe Geschwindigkeiten zu erreichen, empfohlen für Geschwindigkeitsdisziplinen. Für sehr nasse Bedingungen.
Base fluorurata soft che consente di raggiungere velocità molto elevate, consigliata per le discipline di velocità. Per condizioni molto umide.

No Fluor
APPROVED



Universal
-8°C > 15°C / 18°F > 60°F

SOLID

- 80 x 30g** REF. 222400
- 80g** REF. 222004
- 13 x 80g** REF. 222005
- 200g** REF. 222100
- 200g LF** REF. 222101
- 500g** REF. 222200
- 5kg** REF. 222401
- 12kg** REF. 222500



LIQUID





- 60ml** REF. 222603
- 8 x 60ml** REF. 222613
- 18 x 60ml** REF. 222623
- 75ml** REF. 222600 \varnothing Dia=35mm / L=15.5cm
- 250ml** REF. 222601 \varnothing Dia=50mm / L=22.5cm
- 1L** REF. 222700
- 5L** REF. 222701



× 33 ×



Universal WAX

-  Les farts VOLA "Universal" s'adressent à tous les skieurs, du débutant au confirmé, recherchant un fart polyvalent compatible avec tous les types de neiges. Selon le conditionnement ils s'adaptent à une utilisation personnelle ou en atelier. Ils participent efficacement à l'entretien des semelles des skis.
-  Vola Universal ski waxes are for all skiers from beginners to advanced who are looking for allround wax for use in any kind of snow. They are available in solid, liquid or flakes forms and are designed for both personal and Rental shop use. They are an efficient means of nourishing and maintaining ski bases.
-  VOLA-Universalskiwachs eignet sich für alle Skifahrer von Anfängern bis zu Profis, welche auf der Suche nach einem vielseitigen Skiwachs für alle Schneearten. Erhältlich in Blockform oder Flüssigwachs ist es sowohl für den Privatgebrauch als auch für Skiverleihe geeignet. Universalwachse tragen zur Pflege der Skibeläge bei.
-  La sciolina VOLA « Universale » è destinata a tutti i tipi di sciatore, dai principianti agli esperti che cercano una sciolina polivalente per tutti i tipi di neve. A seconda delle condizioni possono essere utilizzate personalmente o in negozio. Contribuiscono alla protezione delle solette.





WAX

Universal WAX



NEW

MYECO WAX

-  MyEcoWax est un fart eco-responsable offrant d'excellentes performances de glisse. Cette gamme hybride, sans fluor, comprend plus de 50% de matières premières d'origine végétales et animales. Son packaging en carton recyclé est 100% biodégradable et recyclable. Toutes les étapes du cycle de vie de MyEcoWax ont été prises en compte pour offrir aux skieurs exigeants une gamme de farts écologiques avec des performances proches des farts à base d'hydrocarbures classiques.
-  My Eco-Wax is an eco-responsible wax offering excellent gliding properties. This hybrid range, fluor-free, includes more than 50% of raw materials from plant and animal origin. Its cardboard packaging is made of biodegradable, recyclable and non-toxic wood fibers. All stages of the MyEcoWax life cycle have been taken into account to offer skiers a range of ecological waxes with performances close to the ones of conventional hydrocarbon waxes.
-  My Eco-Wax ist ein umweltfreundliches Wachs mit hervorragenden Gleiteigenschaften. Dieses fluorfreie Hybridsortiment enthält mehr als 50% Rohstoffe pflanzlichen und tierischen Ursprungs. Die Kartonverpackung besteht aus biologisch abbaubaren, recycelbaren und ungiftigen Holzfasern. Alle Phasen des MyEcoWax-Lebenszyklus wurden berücksichtigt, um Skifahrern eine Reihe ökologischer Wachse mit Leistungen anzubieten, die denen herkömmlicher Kohlenwasserstoffwachse nahe kommen.
-  My Eco-Wax è una sciolina eco-responsabile che offre eccellenti prestazioni di scivolamento. Questa gamma ibrida, priva di fluoro, comprende oltre il 50% di materie prime di origine vegetale e animale. La sua confezione di cartone è realizzata con fibre di legno biodegradabili, riciclabili e non tossiche. Tutte le fasi del ciclo di vita di MyEcoWax sono state prese in considerazione per offrire agli sciatori esigenti una gamma di scioline ecologiche con prestazioni simili a quelle delle scioline tradizionali di idrocarburi.

MyEcoWax

FREE FLUOR



Sun
Air -2°C > 10°C / 28°F > 50°F
200g / Ref 221904

Eco-Responsible

Ruby
Air -5°C > 0°C / 23°F > 32°F
200g / Ref 221903

Lavender
Air -12°C > -4°C / 10°F > 25°F
200g / Ref 221902

Ocean
Air -25°C > -10°C / -13°F > 10°F
200g / Ref 221901





No Fluor

Made in France

nice!



E-WAX

-  L'E-Wax est le fart le plus respectueux de l'environnement développé par VOLA. Sans fluor, il intègre plus de 95% de matières premières d'origine animale et végétale. Son emballage est 100% végétal donc bio-dégradable et peut être composté. L'encre utilisée ne contient aucun métaux lourds. L'E-Wax conviendra parfaitement à tous les types de skieurs et à tous les ateliers de fartages. Il peut se crayonner ou s'appliquer à chaud.
-  E-WAX is the most environmentally friendly wax developed by VOLA. Without fluor, it incorporates more than 95% of raw materials from animal and vegetable origin. Its packaging is 100% vegetable, therefore bio-degradable and can be composted. The ink used does not contain any heavy metals. The E-WAX is perfect for all types of skiers and all waxing workshops. It can be rub on or applied by hot waxing.
-  E-WAX ist das umweltfreundlichste Wachs, das VOLA entwickelt hat. Ohne Fluor enthält es mehr als 95% der Rohstoffe tierischen und pflanzlichen Ursprungs. Die Verpackung besteht zu 100% aus pflanzlichen Rohstoffen, ist daher biologisch abbaubar und kann kompostiert werden. Die verwendete Tinte enthält keine Schwermetalle. Das E-WAX ist perfekt für alle Arten von Skifahrern und alle Wachsworkstätten. Es kann eingerieben oder heiß gewachst werden.
-  E-WAX è la sciolina più ecologica sviluppata da VOLA. Senza fluoro, incorpora oltre il 95% di materie prime di origine animale e vegetale. La sua confezione è al 100% vegetale, quindi biodegradabile e può essere compostata. L'inchiostro utilizzato non contiene metalli pesanti. L'E-WAX è perfetto per tutti i tipi di sciatori e per tutti i laboratori di sciolinatura. Può essere strofinato o applicato a caldo.

FREE FLUOR



E-Wax

air : -10°C > 10°C / 14°F > 50°F

- 80g REF. 522005
- 80x30g REF. 522400
- 200g REF. 522100
- 500g REF. 522200
- 10kg REF. 522405

contient 95% de cires végétales et animales
contains 95% of vegetable and animal waxes



impression du packaging
à l'encre à l'eau sans métaux lourds
printing of the packaging
heavy metal free water based ink

toile de jute / burlap :
packaging 100% végétal

fabriqué en / made in
France!



Klister WAX & Kick WAX



K40 REF. 225300

Klister Bleu pour neiges glacées et températures de neige très froides de -14°C à -5°C.
Blue Klister for icy snow and cold snow temperatures from -14°C to -5°C.
BlueKlister für eisigen Schnee im angegebenen Schneetemperaturbereich : -14°C / -5°C
Sciolina di tenuta in pasta per nevi trasformate e mista artificiali a cristallo grosso. Neve temperatura : -14°C / -5°C



K41 REF. 225301

Klister Violet pour neiges transformées et humides. Températures de neige allant de -6°C à -3°C.
Violet Klister for humide snow and snow temperatures from -6°C to -3°C.
VioletKlister für eisigen Schnee or feuchtem Schnee im angegebenen Schneetemperaturbereich : -6°C / -3°C.
Sciolina di tenuta in pasta per nevi trasformate e mista artificiali a cristallo grosso. Neve temperatura : -6°C / -3°C;



K42 REF. 225302

Klister Rouge pour neiges transformées, très humides autour du point de congélation. Haute qualité de glisse. Températures de neige de -3°C à 0°C.
Red klister for very humide snow, close to the frozen point and snow temperatures from -3°C to 0°C.
RedKlister für feuchtem Schnee im angegebenen Schneetemperaturbereich : -3°C / 0°C
Sciolina di tenuta in pasta per nevi trasformate e mista artificiali a cristallo grosso o bagnato. Neve temperatura : -3°C / 0°C.



K43 REF. 225303

Klister Vert pour neiges glacées et températures de neige très froides de -20°C à -10°C. Peut être utilisé en base pour améliorer la tenue des autres klister.
Green klister for icy snow and extremely cold snow temperatures from -20°C to -10°C. Could be used as a base to improve the durability of other klister.
GreenKlister für eisigen Schnee im angegebenen Schneetemperaturbereich : -20°C / -10°C. Auch utlisiert als Grundlage für die anderen Klister.
Sciolina di tenuta in pasta per nevi caldi e mista artificiali a cristallo grosso. Neve : -20°C / -10°C. È possibile di utlisiere come una base.



K44 REF. 225304

Klister Argent pour neiges transformées autour du point de congélation. Température de neige : de -1°C à 0°C.
Silver klister for transformed snow around the frozen point. Snow temperatures : from 0°C to +5°C.
SilverKlister für eisigen Schnee im angegebenen Schneetemperaturbereich : -1°C / 0°C.
Sciolina di tenuta in pasta per nevi trasformate e mista artificiali a cristallo bagnato. Neve temperatura : -1°C / 0°C.



Zéro degré LF - 75ml REF. 225305

Fart liquide fluoré pour skis à peaux ou micro-pores. Anti-ice, il permet d'améliorer la glisse et de protéger les peaux.
Special Liquid ski wax with fluor additive. Made for skins or for skis with micro-pores. Anti-freeze, it allows to improve gliding and/or to protect the skins.
Fluorierte Flüssigwachs für den Steigbereich der Langlauf zero Ski. Gemacht für die Steigzone.
Sciolina speciale per sci «zero degree». Anticongelante, da applicare sulla zona di tenuta per improvare la velocità.



P43 REF. 225403
-20°C / -10°C

45g. Fart de retenue pour neiges fraîches et tombantes et températures de neige très froides. Peut être utilisé en base pour améliorer la tenue des autres poussettes.
45g. Grip wax for fresh or falling snow and very cold snow. Could be used as a base to improve the durability of other sticks.
45g. Bei sehr kalten Verhältnissen, für NeueSchnee. Auch utlisiert als Basis für die anderen Gripwachs.
45g. Sciolina di tenuta per nevi cadenti, nevi fresca e miste artificiali a cristallo fine o poco trasformate. È possibile di utlisiere il stick Green come una base.



P40 REF. 225400
-11°C / -5°C

45g. Poussette Bleu. Fart de retenue pour neiges fraîches ou tombantes et températures froides.
45g. Blue stick. Grip wax for fresh or falling snow and cold snow temperature.
45g. Blau Gripwachs. Bei kalten Verhältnissen. Für Neuschnee.
45g. Sciolina di tenuta per nevi cadenti, nevi fresca e miste artificiali a cristallo fine o poco trasformate.



P45 REF. 225405
-11°C / -5°C

45g. Poussette Bleu Extra. Similaire à la P40 mais meilleure sur les neiges vieilles.
45g. Blue stick Extra. Same as the P40 but more efficient on old snows.
45g. Blue Gripwachs Extra. Gleich wie der P40 aber effizienter auf alten Schnee.
45g. Uguale al P40, ma più efficace su neve vecchia.



P41 REF. 225401
-5°C / -1°C

45g. Poussette Violet. Fart de retenue pour neiges fraîches ou tombantes.
45g. Violet stick. Grip wax for fresh or falling snow and intermediate snow temperature.
45g. Violett Gripwachs. Bei trockenem Schneefall und feinkörnigem, neuem Schnee.
45g. Sciolina di tenuta per nevi cadenti, nevi fresca e miste artificiali a cristallo fine o poco trasformate.



P46 REF. 225406
-5°C / -1°C

45g. Poussette Violet Extra. Similaire à la P41 mais meilleure sur les neiges vieilles.
45g. Violet stick Extra. Same as the P41 but more efficient on old snows.
45g. Violet Gripwachs. Gleich wie der P41 aber effizienter auf alten Schnee.
45g. Uguale al P41, ma più efficace su neve vecchia.



P42 REF. 225402
-2°C / 0°C

45g. Poussette Rouge. Fart de retenue pour neiges fraîches ou tombantes et températures de neige proches du point de congélation.
45g. Red stick. Grip wax for use in fresh or falling snow, on icy tracks and high snow temperature.
45g. Red Gripwachs. Bei feuchtem Neuschnee, Schneefall, bei nicht glasig werdender Spur.
45g. Sciolina di tenuta per nevi cadenti, nevi fresca e miste artificiali a cristallo fine o poco trasformate.



P44 REF. 225404

45g. Poussette Universel. Fart universel de retenue pour neiges fraîches ou tombantes.
45g. All-round stick. Grip wax for fresh or falling snow. Ideal for beginners, easy and quick to use.
45g. Allround Gripwachs für Neuschnee und Schneefall. Sehr gut für den Einsteiger, einfach in der Anwendung.
45g. Sciolina universale di tenuta per nevi cadenti, nevi fresca e miste artificiali a cristallo fine o poco trasformate. Molto facile da utlisiere per tutti i tipi di sciatore che cercano una sciolina di tenuta polyvalente per tutti i tipi di neve.

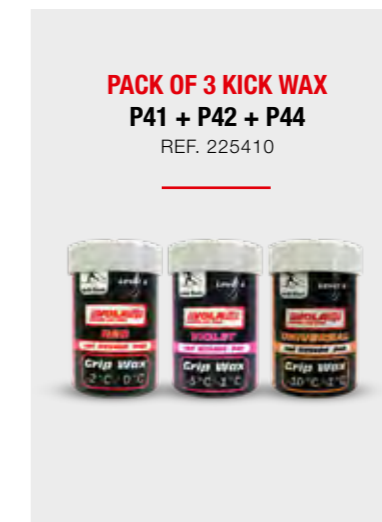

PACK OF 3 KICK WAX
P41 + P42 + P44
REF. 225410

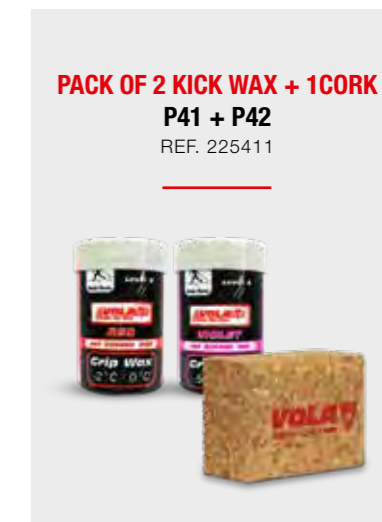

PACK OF 2 KICK WAX + 1 CORK
P41 + P42
REF. 225411



Remover WAX



× 40 ×



R021 / 200g REF. 229100

Paraffine à défarter R021. 200 g. Fart très tendre composé uniquement de paraffines à coefficient de fusion très faible lui procurant une fluidité exceptionnelle. Utilisé lors du raclage à chaud, le R021 permet de nettoyer la semelle en profondeur et de dilater les pores de la semelle afin d'augmenter la rétention des farts de glisse. Peut être utilisé avant chaque fartage.

Parafin R021. Very soft wax composed entirely of paraffins with melting very low coefficient, giving it exceptional fluidity. Used when hot-scraping, R021 cleans the base depth and open the pores of the base to increase the retention of gliders. Can be used before each waxing.

Parafin R021. Sehr weiches Wachs ganz von Paraffinen mit Schmelz sehr niedrigen Koeffizienten ihm außergewöhnlichen Flüssigkeit besteht. Wird verwendet, wenn Schaben heiß, reinigt R021 die Sohlentiefe und öffnen die Poren der Sohle, um die Retention von Segelflugzeugen zu erhöhen. Kann vor jedem Wachsen verwendet werden.

Paraffina di pulizia. R021. Sciolina molto morbido composto interamente di paraffine con fusione bassissimo coefficiente dando fluidità eccezionale. Utilizzato quando raschiando caldo, R021 pulisce la suola di profondità e aprire i pori della suola per aumentare la ritenzione di allanti. Può essere usato prima di ogni ceretta.



250ml REF. 229601
1L REF. 229700
5L REF. 229701

Spécial alpin. Défarreur liquide.
 Alpine. Liquide wax remover.
 Flüssigwachsreiniger.
 De-sciolinatore liquido.



250ml REF. 229603
1L REF. 229702

Spécial Nordique. Défarreur liquide.
 Nordic. Liquide wax remover.
 Nordische Flüssigwachsreiniger.
 De-sciolinatore nordico liquido.



250ml REF. 229602 - FLUORCLEAN
1L REF. 229703 - FLUORCLEAN

Défarreur liquide 1 L. Pour une remise à zéro des skis après un fartage avec du fart fluoré.
 Liquide wax remover 1 L. For cleaning the ski base after waxing with fluorinated wax.
 Flüssigwachsreiniger 1 L. Zur Reinigung der Belag nach dem Wachsen mit fluorierten Wachs.
 De-sciolinatore liquido 1 L. Per la pulizia della soletta dopo la ceretta con cera fluorurati.



150ml aerosol REF. 229610

Défarreur liquide 150ml aérosol. Pour la vente grand public et les écoles de ski.
 Liquid wax remover 150ml aerosol. For consumer sale and ski schools.
 Flüssigwachsreiniger 150ml Sprühdose. Für Einzelhandel und Skischulen.
 De-sciolinatore liquido 150ml Aerosol. Per la vendita al pubblico e per le scuole sci.



× 41 ×

ACCESSORIES



AFFÛTAGE × SHARPENING × KANTENSCHLEIFZUBEHÖR × AFFILATURA



Adjustable Base Edge REF. 011027

Base Edge pour tomber les carres. Réglable de 0,5° à 1,5°.
 Base edge for a precise level on the base edge. Adjustable from 0,5° to 1,5°.
 Base Edge, verstellbar für das belagseitige Einschleifen 0,5° bis 1,5°.
 Base Edge regolabile. Da 0,5° a 1,5°.



Base Edge

Base Edge pour tomber les carres côté semelle.
 Base edge for a precise level on the base edge.
 Base Edge, verstellbar für das belagseitige Einschleifen.
 Base Edge.
 REF. 011118 - BASE EDGE 0.5°
 REF. 011119 - BASE EDGE 0.75°
 REF. 011120 - BASE EDGE 1°



Racing File Guide

Equerre Racing. REF. 011021 - 88°
 Racing file guide. REF. 011022 - 87°
 Racing Kantenwinkel.
 Squadretta Racing.



PRO WC Guide

Equerre Pro. REF. 011015 - 90°
 Pro guide. REF. 011016 - 89°
 Pro Kantenwinkel. REF. 011017 - 88°
 Squadretta Pro. REF. 011018 - 87°
 REF. 011019 - 86°
 REF. 011020 - 85°



Pro Sidewall Tool REF. 011051

Outil pour chant PRO. Livré avec une lame ronde pour chants inclinés et une lame carrée pour chants droits.
 Pro Sidewall tool. Delivered with one round blade for inclined edges and one square blade for straight edges.
 Seitenwangenabzieher. Lieferung mit einem Rundmesser für schrägen Kanten und einem Quadrat Messer für gerade Kanten.
 Utensile per lo spigolo PRO. Consegnato con una lama rotonda per gli spigoli inclinati e una lama quadra per spigoli dritti.



Sidewall Carrot Pro REF. 011136

Outil pour chant électrique, compact et ergonomique.
 Livré avec la lame Medium (GS/SL).
 Electric Sidewall tool, compact and ergonomic. Supplied with medium blade (GS/SL).
 Elektronisches Seitenwangenfräsgerät, ergonomisch und kompakt. Ausgestattet mit einer mittleren Klinge (GS/SL)
 Utensile per la lamina elettrica. In dotazione viene fornito con una mola media (GS/SL)



Ergorazor REF. 011052

Outil pour chant à lame ronde permettant de nombreux réglages. Simple et économique.
 Sidewall tool with a round blade allowing different adjustments. Cheap and easy to use.
 Seitenwangenabzieher mit rundem Messer und verschiedenen Einstellmöglichkeiten. Leicht zu benutzen.
 Utensile per lo spigolo a lama rotonda che consente numerose regolazioni. Semplice ed economico.



Racing Sharp REF. 011083

Affûteur de 89° à 86° + mise à plat du ski 0,5° et 1°.
 Sharpener from 89° to 86° + base edge from 0,5° to 1°.
 Kantenwinkel von 89° bis 86° + Base edge 0,5° und 1°.
 Affilatore da 89° a 86° + Base edge da 0,5° e 1°.



88°/89°

Quick Sharp Basic REF. 011004

Affûteur de poche + Lime
 Pocket sharpener + File
 Kantenwinkel + Feile
 Affilatore tascabile + Lima



Vendu en présentoir de 8 pièces
 Sold in display of 8 pieces

Easy Sharp Basic REF. 011006

Affûteur de poche + Lime
 Pocket sharpener + File
 Kantenwinkel + Feile
 Affilatore tascabile + Lima

Quick Sharp Extra REF. 011005

Affûteur de poche + Lime + Diamant + Abrasive
 Pocket sharpener + File + Diamond + Abrasive
 Kantenwinkel + Feile + Diamantfeile + Abrasive
 Affilatore tascabile + Lima + Pietre diamantate + Abrasive

Easy Sharp Extra REF. 011008

Affûteur de poche + Lime + Diamant + Abrasive
 Pocket sharpener + File + Diamond + Abrasive
 Kantenwinkel + Feile + Diamantfeile + Abrasive
 Affilatore tascabile + Lima + Pietre diamantate + Abrasive

Carrot Machine REF. 011108

Machine à affûter à pierre Carrot pour skis alpins et snowboard. Livré avec une équerre 87° et 88° et une meule 120. Permet d'affûter le côté chant du ski.
 Electric rotative stone side edge sharpener for ski & snowboard tuning. Delivered with 87° and 88° guides and a stone 120. Allow to tune the edge side.
 Elektrisch rotierender Stein in Schräglage, zum Schärfen der Kanten von Alpinskiern und Snowboards. Geliefert mit einem 87° & einem 88° Winkel, dem 120er Allroundstein, Netzadapter und Schleifgerät.
 Macchina affilalamine per sci e snowboard. Fornita con squadretta 87 e 88° e mola diamantata di grana 120.



- REF. 011124 STONE 80
- REF. 011109 STONE 120
- REF. 011125 STONE 240
- REF. 011126 STONE 320
- REF. 011127 STONE 500
- REF. 011110 STONE CERAMIQUE
- REF. 011111 STONE DIAMOND

- REF. 011112 CORNER 89
- REF. 011113 CORNER 88
- REF. 011114 CORNER 87
- REF. 011115 CORNER 86



× 44 ×



- 1 **Ergoss Sharp** REF. 011130
- 2 **Ergoss Racing** REF. 011131

Affûteur réglable de 90° à 85°.
 Sharpener from 90° to 85°.
 Kantenwinkel Schleifgradeinstellung 90°- 85°.
 Affilatore regolabile 90°- 85°.



Accessories REF. 011033

Pince de fixation.
 File clamp.
 Halteklammer.
 Pinza di fissaggio.



Accessories REF. 011047

Carde à lime.
 File card.
 Feilenbürste mit Messingborsten.
 Spazzola per lima.

× 45 ×

AFFÛTAGE × SHARPENING × KANTENSCHLEIFZUBEHÖR × AFFILATURA

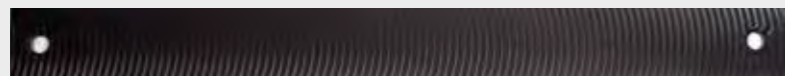

REF. 011034
Lime 300 mm.
300 mm File.
Karosseriefeile 300 mm.
Lima 300 mm.



REF. 011035
Lime double taille 150 mm.
150 mm Double cut File.
150 mm Maxifeile.
Lima doppio taglio.

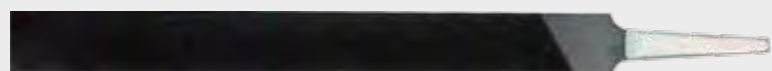

REF. 011038
Lime 200 mm Cut 1.
200 mm File Cut 1.
200 mm Feile Cut 1.
Lima 200 mm Cut 1.



REF. 011036
Lime 150 mm Cut 2.
150 mm File Cut 2.
150 mm Feile Cut 2.
Lima 150 mm Cut 2.

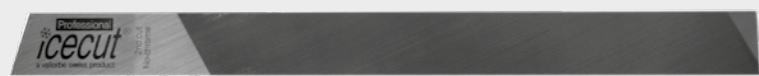

REF. 011039
Lime 200 mm Second cut.
200 mm File Second cut.
200 mm Feile Second cut.
Lima 200 mm Second cut.



REF. 011037
Lime 150 mm Cut «Smooth».
150 mm File Cut «Smooth».
150 mm Feile Cut «Smooth».
Lima 150 mm Cut «Smooth».

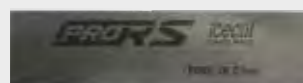

REF. 011071
Lime Pro RS; 10cm.
PRO RS File; 10cm.
PRO RS Feile; 10cm.
Lima PRO RS; 10cm.

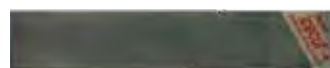

REF. 011032
Lime demi-douce de rechange.
Spare half cut file.
Erzatzfeile.
Lima semi-dolce di ricambio.



REF. 011058 - FINE
REF. 011059 - MEDIUM
Lime Racing.
Racing File.
Racing Feile.
Lima Racing.

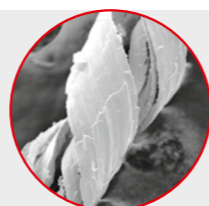

FINITION × FINISHING × FEINTUNING × FINITURA



Diamond Plate
REF. 011043 COARSE (200)
REF. 011044 STANDARD (400)
REF. 011045 FINE (600)
REF. 011046 VERY FINE (1000)

VOLA Plaquette diamantée.
VOLA Diamond plate.
VOLA Diamantfeile mit Plakette
VOLA Pietre diamantate.



Diamond Plate ICECUT
REF. 011075 COARSE (200)
REF. 011076 STANDARD (400)
REF. 011077 FINE (600)
REF. 011078 VERY FINE (1000)

Plaquette diamantée Icecut.
Icecut Diamond plate.
Icecut Diamantfeile mit Plakette.
Pietre diamantate Icecut.

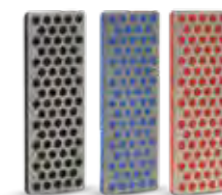

Small Diamond Plate
REF. 011040 BLACK
REF. 011041 BLUE
REF. 011042 RED

Lime diamant petit modèle.
Small diamond stone.
Kleine Diamantfeile.
Lima diamantata piccola.



Arkansas Plate
REF. 011049 ARKANSAS HARD
REF. 011050 ARKANSAS EXTRA HARD

Pierre Arkansas dure et très dure. Finition standard et finition course.
Arkansas Hard and Extra Hard stone. For finishing and racing service.
Arkansas Naturalstein, hart und sehr hart.
Pietra Arkansas dura e molto dura. Finitura standard e finitura gara.



Abrasive Block
REF. 011002
Gomme extra dure. Pour les clubs et l'atelier.
Extra hard rubber abrasive block. For clubs and the workshop.
Kantenbrechgummi hart, für Skiclubs.
Gomma molto dura. Per i club e i negozi.



Basic Plate
REF. 011048
Pierre plate. Pierre basique.
Basic oxide alu stone.
Alu-Oxyd-Stein, Universal.
Pietra piana. Pietra base.



FINITION × FINISHING × FEINTUNING × FINITURA



Plastic Scraper

REF. 012001 / 4MM
REF. 012002 / 3MM
REF. 012062 / 3MM CRYSTAL
REF. 012004 / SNOWBOARD 6MM
REF. 012024 / NORDIC

Racle plastique.
Plastic scraper.
Wachsabziehklinge aus Plexiglas.
Spatola.



3mm + 4mm

Pro Sharpener REF. 011003

Affûte-racles PRO.
PRO scraper sharpener.
PRO Schleift Schärfe.
Arrotino per spatole PRO.



Metal Scraper REF. 012003

Racle métallique pour la mise à plat et lors de la réparation avec une bougie.

Metal Scraper for base repair and planification.
Metallabziehklinge.

Spatola in metallo per spianare la soletta e per riparazioni.



3mm + 4mm + 5mm

Basic Sharpener REF. 011079

Affûte-racles basique.
Basic scraper sharpener.
Basic Schleift Schärfe.
Arrotino per spatole basico.



Metallic Planificator REF. 012005

Planimètre et racle métallique. Permet de vérifier si le ski est à plat.

Metallic Planificator. Used to control the flatness.
Haarlineal Alpin, für die Ebenheitskontrolle des Belags.

Utensile con spatola metallica. Per controllare la planarità della soletta.



Carrot Sharpener REF. 011116

Affûte-racles électrique.
Electrical scraper sharpener.
Elektroschleift Schärfe.
Arrotino per spatole elettrico.

BROSSAGE × BRUSHING × WACHSBÜRSTE × SPAZZOLATURA



Fine Steel REF. 012033

Brosse Fine Steel. A utiliser avant le fartage pour nettoyer la semelle en profondeur et tout de suite après le raclage. Indispensable pour les farts liquides.

Fine Steel brush. To be used after the tuning to clean deeply the base and after the waxing in first position. Very efficient for the liquid waxes.

Fine Steel Wachsbürste. Geeignet für das Säubern des Belags in der Tiefe nach der Kantenbehandlung und nach dem Wachs am erste Bürste. Sehr important mit die Flüssiwachs.

Spazzola Fine Steel. Utilizzata per la pulizia della soletta in profondità dopo avere fatto le lamine e in primo dopo la sciolina. Molto importante dopo la sciolina liquida.



Brass/Nylon Brush REF. 012007

Brosse Nylon/Bronze. 2 en 1. Association des brosses 012006 et 012009.

Brass / Nylon brush. Two in one.
Nylon- und Bronzewachsbürste.

Spazzola Nylon / Bronzo. Include in un unico articolo le spazzole 012006 e 012009.



Nylon Soft/Felt REF. 012074

× 48 ×

LIÈGE / CORK / KORK / SUGHERO



REF. 012012 - LIÈGE
REF. 012055 - SYNTHETIC



ROTO BRUSH REF. 012023



FELT/CORK REF. 012011

BRASS BRUSH

Brosse bronze à poils longs et fins. Elle permet de désoxyder et de nettoyer la semelle avant le fartage. Elle est également utilisée tout de suite après le raclage pour retirer le fart en excès.

Brass brush with long and fine hairs. It allows deoxidizing and clean the base before waxing. It is also used immediately after scraping to remove the excess wax.

Bronzewachsbürste. Geeignet für das Säubern des Belags nach der Kantenbehandlung und nach dem Wachs.

Spazzola bronzo. Utilizzata per la pulizia della soletta dopo avere fatto le lamine e dopo la sciolina.



REF. 012009



REF. 012035

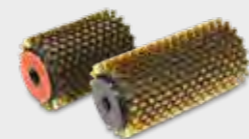

REF. 012020 (RED CREEK-100MM)
REF. 012053 (VOLA - 140MM)

NYLON BRUSH

Brosse nylon en polyamide à poils moyens et larges. À utiliser comme 2ème brosse après le raclage. Elle permet de polir la semelle et de lui donner un aspect le plus lisse possible afin de réduire la friction avec la neige.

Nylon brush made in polyamide with medium and long hairs. To be used in second position after the scraping. Made to smooth the base as much as possible to reduce friction with the snow.

Nylonwachsbürste. Eignet sich nach dem Wachs und nach die Bronzewachsbürste um die Skibeläge zu glätten.

Spazzola nylon. Utilizzata dopo la sciolina e dopo la spazzola bronzo per lisciare la soletta.



REF. 012006



REF. 012034

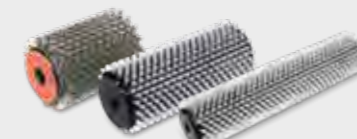

REF. 012019 (RED CREEK-100MM)
REF. 012052 (VOLA - 140MM)
REF. 012061 (VOLA - SNOWBOARD)

HORSEHAIR BRUSH

Brosse à poils courts et fins. Brosse de finition à utiliser en dernière position. Sa composition en crin de cheval permet de lustrer la semelle et lui confère des qualités antistatiques qui améliorent la glisse.

Horsehair brush with short and fine hairs. Its composition will polish the base and give best gliding properties because of its antistatic qualities. To be used before the race.

Rosshaarwachsbürste. Eignet sich bevor die Rennen, um die Skibeläge zu lustrieren.

Spazzola in crine di cavallo. Utilizzata davanti la gara per lustrare la soletta.



REF. 012010



REF. 012046



REF. 012021 (RED CREEK-100MM)
REF. 012054 (VOLA - 140MM)
REF. 012067 (VOLA - SNOWBOARD)



Brass/Horsehair REF. 012057

Brosse ovale Bronze Hard / Crin de cheval.
Oval brush. Hard brass / Horsehair.
Ovale Rennservicebürste. Hart Bronze/Rosshaar.
Spazzola ovale. Bronzo duro / Crine di cavallo.



Nylon/Horsehair REF. 012025

Brosse ovale Nylon/Crin de cheval.
Oval brush. Nylon/Horsehair.
Ovale Rennservicebürste Nylon/Rosshaar.
Spazzola ovale Nylon/Crine di cavallo.



Nylon Soft REF. 012058

Brosse ovale Nylon soft.
Oval brush. Nylon soft.
Ovale Rennservicebürste Nylon soft.
Spazzola ovale Nylon soft.



100 mm

1 Soft Nylon Roto Brush

REF. 012070

2 Fleece Roto Brush

REF. 012071

Roto Brush Stem

REF. 012018 (100MM)
REF. 012051 (VOLA-140MM)
REF. 012047 (VOLA-SNOWBOARD)

Axe pour brosse rotative.
Roto Brush Stem.
Achse für Rundbürste als Aufsatz für die Bohrmaschine.
Maniglia per spazzole rotative.



× 49 ×

RÉPARATION × **REPAIR** × AUSBESSERUNGSMATERIAL × **RIPARAZIONE**



Repair Pistol REF. 013018 240V / 400W / 50Hz

Pistolet de réparation grand public.
Public base repair pistol.
Consumer Repair Pistole.
Pistola Riparazione dei consumatori.

Ø Dia = 11,5mm / L = 10cm / Qty = 3pcs



Base Repair Pistol REF. 013010 220-240V / 285W

Pistolet de réparation pour l'atelier. Développée spécialement pour le naltène, sa buse permet une fonte et une application idéale de la bougie (diamètre bougie: 11.5mm).
Base repair pistol. Developed especially for the naltene, it allows a good melting and a good application of the candle (candle diameter: 11.5mm).
Belagsausbesserungspistole. Besonders für den Belagsausbesserungsstifte entwickelt, erlaubt er gutes Schmelze und eine gute Anwendung (Durchmesser: 11.5mm).
Pistola di riparazione. Sviluppato specialmente per il naltene, permette una buona fusione e una buona applicazione delle candele (candela diametro: 11.5mm).



Roller Waxer REF. 012056

Machine à farter au rouleau. Facile à utiliser. Idéal pour l'atelier et les écoles de ski.
Roller waxer. Easy to use and ideal for shops and ski schools.
Wachsmaschine. Leicht zu bedienen, für Skigeschäfte und Skischulen.
Attrezzo sciolatore a rullo. Facile da usare. Ideale per negozi e scuole sci.

220V / 400W



Vola Iron REF. 012017

230V / 1000W / 50Hz
120V / 800W / 60Hz

Fer à farter VOLA. Ce fer à farter est entièrement réglable et très ergonomique. Du fait de sa faible taille et de ses performances, ce fer deviendra un outil facilement transportable.

VOLA waxing iron. Completely adjustable and ergonomic. Because of its quality and small size, this iron is an easily transportable tool.

VOLA Wachsbugelisen. Dieses Wachsbugelisen ist völlig regulierbar und ergonomisch. Wegen seiner kleinen Größe und der hohen Leistungen ist es eine Alternative für Reisende.

Ferro sciolatore VOLA. Interamente regolabile e molto ergonomico. Grazie alle sue dimensioni a caratteristiche è l'ideale per chi effettua frequenti spostamenti.



Iron Holder REF. 012080 **NEW**

BOUGIE / CANDLE / BELAGSAUSBESSERUNGSSTIFTE / CANDELE



REF. 013016 - GRAPHITE
REF. 013017 - WHITE

Bougie de réparation à brûler. (x3)
P-tex candle for base repairs. To be burn. (x3)
Belagsausbesserungsstifte mit dem Feuerzeug eintropfen lassen. (x3)
Candele di riparazione, da bruciare. (x3)

Ø Dia = 8mm / L = 19.5cm / Qty = 3pcs

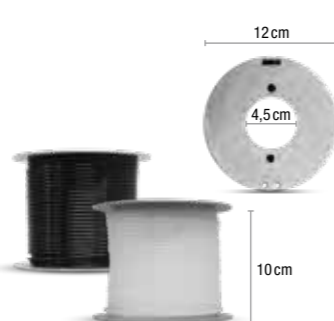

REF. 013001 - BLACK / 0.4 KG
REF. 013003 - WHITE / 0.4 KG

Bobine de réparation noire ou incolore.
Roll of P tex black or transparent.
Belagsausbesserungsdraht, schwarz oder transparent.
Bobina di riparazione nera o incolore.

Ø Dia = 3mm

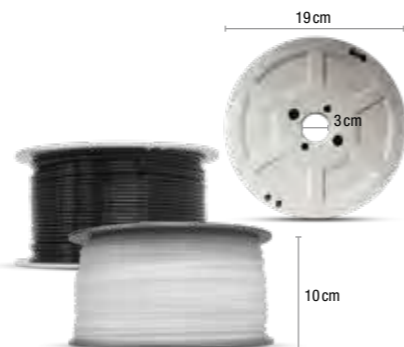

REF. 013002 - BLACK / 1.5 KG
REF. 013004 - WHITE / 1.5 KG

Bobine de réparation noire ou incolore.
Roll of P tex black or transparent.
Belagsausbesserungsdraht, schwarz oder transparent.
Bobina di riparazione nera o incolore.

Ø Dia = 3mm



REF. 013007 - BLACK 10 CANDLES
REF. 013008 - WHITE 10 CANDLES

Bougie de réparation pour pistolet.
P-tex candle for repair pistol.
Belagsausbesserungsstifte für Pistole.
Candela di riparazione per pistola.

Ø Dia = 11,5mm / L = 14,5cm



REF. 013019 - BLACK 1KG
REF. 013020 - WHITE 1KG

Bougie de réparation pour pistolet.
P-tex candle for repair pistol.
Belagsausbesserungsstifte für Pistole.
Candela di riparazione per pistola.

Ø Dia = 11,5mm / L = 14,5cm



REF. 013014 - BLACK 1KG
REF. 013015 - WHITE 1KG

Bougie de réparation à brûler.
P-tex candle for base repairs. To be burn.
Belagsausbesserungsstifte mit dem Feuerzeug eintropfen lassen.
Candele di riparazione, da bruciare.

Ø Dia = 8mm / L = 19,5cm

FERS × **WAXING IRONS** × WACHSBÜGELEISEN × **FERRI SCIOLINATORI**



Digital Iron REF. 012015

230V / 1000W / 50Hz

Fer à farter digital. Contrôle de la température électronique de 0°C à 200°C.
Digital waxing iron. Electronic temperature control with digital display from 0° to 200°C.
Wachsbugelisen. Genaue Electronische Kontrolle der Temperatur. Von 0°C bis 200°C.
Ferro sciolatore. Controllo elettronico preciso della temperatura. Da 0°C e 200°C.



Digital Pro Iron REF. 012068

230V / 1000W / 50Hz

Fer à farter digital avec semelle épaisse. Contrôle de la température électronique de 0°C à 200°C.
Digital waxing iron with thick sole. Electronic temperature control with digital display from 0° to 200°C.
Wachsbugelisen. Genaue Electronische Kontrolle der Temperatur. Von 0°C bis 200°C.
Ferro sciolatore digitale con suola spessa. Controllo elettronico preciso della temperatura. Da 0°C e 200°C.

ThermoJomax

REF. 012030 - ALPINE / REF. 012031 - NORDIC

Housse ThermoJomax. Développée pour chauffer vos semelles une fois fardées à la température de 60°C, la ThermoJomax permet d'imprégner vos semelles à l'aide d'un fart d'imprégnation tel qu'un MX rouge ou un MX901. Faire des cycles de chauffage d'environ 30 min pour les skis alpins et 20 min pour les skis de fond.

ThermoJomax. Developed to feed the base of the skis, the ThermoJomax will heat the ski at the temperature of 60°C. Recommended wax: MX Red or MX901. Let it heat for 30 min for alpine skis and 20 min for nordic skis.

ThermoJomax. Die professionelle und einfache Art den Belag mit Basiswachs auf eine gute Tiefenwirkung zu bringen. Nach dem auftragen des Basiswachses mit dem Wachseisen werden die Beläge bei einer Temperatur von 60°C mit dem Thermo Jomax durchgewärmt, das Basiswachs kann dadurch tiefer in den Belag eindringen, Verbesserung der Gleiteigenschaft und Verbrennungen am Belag werden verhindert. Empfehlen Wachs: MX Rot oder MX901. Durchwärme Zeit ca. 30 Min für Alpine und 20 Min für Langlauf Ski.

ThermoJomax. Sviluppato per favorire la penetrazione della sciolina nella soletta, ThermoJomax riscalda lo sci fino ad una temperatura di 60°C. Sciolina raccomandata: MX rosso o MX901. Lasciare agire per 30 min per alpine e 20 min per sci di fondo.



220-240V / 50Hz

TABLES DE FARTAGE × WAX TABLES × WACHSTISCHE × TAVOLI



Start Table REF. 016022
Largeur/Width 8 Longueur/Length 111 Hauteur/Height 85

Etabli de transport Pro. Bon compromis poids / stabilité pour travailler en ski-room grâce à ses patins anti-dérapants et idéal pour les départs des courses grâce à sa légèreté.

Professional transport wax table. Good compromise weight / stability for the ski-room thanks to its skates non skid and ideal for the departures of the races, thanks to its thoughtlessness.

Transport Wachstafel Pro. Guter Kompromiss Gewicht / Stabilität, um in der Workshop dank seiner Schlitsschuhen zu arbeiten, die rutschfest ist. Und Ideal für die Abfahrten der Rennen dank seiner Leichtigkeit.

Tavolo da trasporto Pro. Il bene compromise peso / stabilità per lavorare nel ski room grazie a sue pattine antiscivolanti e ideale per le partenze delle gare grazie alla sua leggerezza.



Transportable Waxing Table REF. 016013
Largeur/Width 10 Longueur/Length 100 Hauteur/Height 80

Table de fartage de transport avec sa housse. Cette table est stable et facile à transporter. Parfaite pour les particuliers.

Transportable wax table with its transport bag. Perfect for home use. Stable and easy to carry.

Wachstafel mit Betriebsanleitung. Diese Tafel ist sehr stabil und einfach zu transportieren. Vollkommen einfach zu bedienen, für Privatpersonen sowie für Kenner geeignet.

Tavolo per sciolinatura da trasporto con il suo zaino. Molto stabile e facile da trasportare. Perfetto per i lavori alla casa.



1 Nordic Table 016031

2 Alpin Table REF. 016037

Nordic & Alpin tables: Largeur/Width 50 Longueur/Length 115 Hauteur/Height 90

Table de fartage Pro. Bon compromis poids/stabilité pour travailler en ski-room et idéal pour les départs des courses grâce à sa légèreté.

Wax table Pro. Good compromise weight/stability for the ski-room and ideal for the departures of the races, thanks to its thoughtlessness.

Wachstafel Pro. Guter Kompromiss Gewicht/Stabilität, um in der Workshop dank seiner Schlitsschuhen zu arbeiten, die rutschfest ist. Und Ideal für die Abfahrten der Rennen dank seiner Leichtigkeit.

Tavolo Pro. Il bene compromise peso/stabilità per lavorare nel ski room e ideale per le partenze delle gare grazie alla sua leggerezza. Tavolo da trasporto Pro. Il bene compromise peso / stabilità per lavorare nel ski room grazie a sue pattine antiscivolanti e ideale per le partenze delle gare grazie alla sua leggerezza.



1 Table REF. 016011
ETABLI/WAX TABLE/ZERLEGBARER WACHSTISCH/TAVOLO
Largeur/Width 47 Longueur/Length 100 Hauteur/Height Adjustable

2 Rack REF. 016012
RÂTELIER/RACK/SKI AUFLAGE/RASTRELLIERA

Etabli démontable et râtelier. Cette table de fartage est très stable et très pratique pour les techniciens qui ont besoin d'une grande table de fartage facilement transportable dans leurs déplacements fréquents.

Wax table with rack. A very stable and practical table, ideal for the technician who needs a good table, easily transportable for travel.

Wachstafel mit Betriebsanleitung. Diese Tafel ist sehr stabil und einfach zerlegbarer Wachstisch. Dieser Wachstisch ist sehr stabil und praktisch, ebenfalls leicht zu transportieren. Daher auch geeignet für Servicemann oder Privatskifahrer, der viel auf Reisen ist.

Tavolo smontabile con rastrelliera. Tavolo per sciolinatura molto stabile e pratico. Ideale per i tecnici che necessitano di un tavolo trasportabile per i loro spostamenti frequenti.

ÉTAUX × VISES × SKISPANNER × MORSE

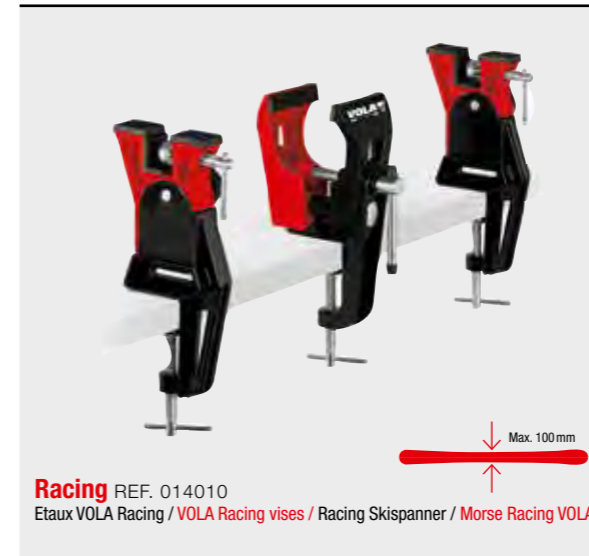

Racing REF. 014010
Etaux VOLA Racing / VOLA Racing vises / Racing Skispanner / Morse Racing VOLA



Trio Compact REF. 014002
Etaux VOLA compact trio / Compact vises VOLA / Skispanner Compact Trio / Morse compact VOLA



Sport REF. 014003
Etaux Sport / Sport ski vises / Skispanner Sport / Morse Sport



1 REF. 014009 / Etau Nordique / Ski vise cross-country / Nordische Skispanner / Morse nordico
2 REF. 014015 / Forme Étau nordique / Nordic Shape Vise / Nordischer Form-Schraubstock / Mise di forma nordica



Universel REF. 014006
Support universel / Universal support / Universal Unterstützung / Supporto universale
For waxing snowboard or cross-country skis with ref 014002 and 014010.



Wide REF. 014012
Etaux WIDE / Wide opening vises / WIDE Pro Skispanner / Morse WIDE

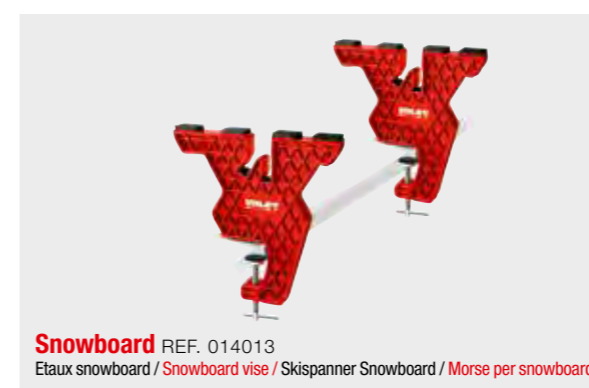

Snowboard REF. 014013
Etaux snowboard / Snowboard vise / Skispanner Snowboard / Morse per snowboard



Double REF. 014004
Double etaux large / Large double vise / Doppelskispanner / Morse doppie larghe.

VOLA BOXES

TUNING KIT ESSENTIAL

REF. 011152

SET INCLUDING:
 Racing file guide 88°
 200mm file
 Diamanded plate 600
 Nylon brush
 Plastic scraper 3mm
 2 brake retainers



NEW

TUNING KIT PLUS

REF. 011153

SET INCLUDING:
 Ergorazor
 Racing file guide 88°
 200mm file
 Diamanded plate 600
 Nylon brush
 Plastic scraper 3mm
 2 brake retainers



NEW

RACE SET

REF. 011086

SET INCLUDING:
 80g LF Blue
 80g LF Purple
 80g LF Red
 80g LF Yellow
 Plastic scraper
 Nordic scraper
 Nylon brush



WAXING KIT

REF. 011057

SET INCLUDING:
 500g MX901
 200g R021
 Wax iron
 Brass brush
 Horsehair brush
 Plastic scraper
 2 brake retainers



NORDIC BOX

REF. 011061

SET INCLUDING:
 200g R021
 80g LF Graphite Base
 200g Medium Base
 Wax iron
 Nylon brush
 Brass brush
 Plastic scraper
 Nordic scraper



× 54 ×

ALPINE SET

REF. 011121

SET INCLUDING:
 500 g MX 901
 200 g R021
 Corner Racing 88°
 File 200mm
 File 150mm
 Vola Diamond plate 600
 Waxing Iron VOLA
 Nylon Brush
 Brass Brush
 Horse Hair Brush
 File Brush
 Scraper 3 mm
 2 break retainers



NEW

MNT 20

REF. 011154

SET INCLUDING:
 80g Base Medium
 200g MX 901
 200g R021
 80g LF Blue
 80g LF Purple
 80g LF Red
 80g LF Yellow
 Waxing Iron VOLA
 Ergorazor
 Racing Corner 88°
 Base Edge
 File 200 mm
 File 150 mm
 Nylon Brush
 Horsehair Brush
 Brass Brush
 Vola Diamond Plate 600
 Lime brush
 Black Candle
 2 Break retainers



NEW

MT 07

REF. 011060

SET INCLUDING:
 200g Base Hard
 200g Base Red
 80g LF Red
 80g HF Red
 200g R021
 150ml aerosol wax remover
 Pro sidewall tool
 VOLA file guide Racing
 300mm file
 200mm file
 150mm file
 Horsehair brush
 Brass brush
 Nylon brush
 4 diamond plates: 200/400/600/1000
 Compact Vice TRIO
 Digital wax iron
 File card
 Scraper sharpener
 Plastic scraper
 2 brake retainers



× 55 ×

NORDIC STRUCTURING TOOLS



VOLA Nordic Structuring REF. 012036

Structureuse manuelle VOLA avec rouleau interchangeable. Pratique et ergonomique, cette structureuse permet de dessiner une nouvelle structure sur les semelles de ski de fond pour améliorer la glisse. Livrée avec le rouleau «diagonal» ref 012041.

VOLA structuring device with interchangeable structure rolls. Easy to use and ergonomic, this device allows you to draw structures on the base of cross country skis. According to the snow conditions, it will increase the glide of the skis. Delivered with diagonal roll ref 012041.

VOLA Strukturroller. Leicht zu benutzen, ergonomisch Belagstrukturiergerät. Das Gerät wird mit der «Diagonal» Rolle ausgeliefert ref 012041.

Ski roll VOLA. Semplice e economico, questo prodotto è consegnato con il roll «diagonal» per nevi intermedie. È possibile di aiutare le strutture lineare e anche in «V». Venduto con il rotolo ref 012041.

V Structure



Coarse warm & wet conditions

REF. 012037 LINEAR COARSE
REF. 012040 DIAGONAL COARSE
REF. 012043 V STRUCTURE COARSE

Diagonal Structure



Medium universal conditions

REF. 012038 LINER MEDIUM
REF. 012041 DIAGONAL MEDIUM
REF. 012044 V STRUCTURE MEDIUM

Linear Structure



Fine cold conditions

REF. 012039 LINEAR FINE
REF. 012042 DIAGONAL FINE
REF. 012045 V STRUCTURE FINE

Speedy ski roller

REF. 012028
Kit A: ZIN-40 + Z2N-33 + Z1N-36

REF. 012029
Kit B: ZIN-40 + Z2N-33 + Z1N-36 + W75-24

 ZIN-40 Special H
-15°C / +3°C Groove width 0.30mm

 Z1N-36 Special H for powder snow
-17°C / +5°C Groove width 0.30mm

 Z2N-33 Special H
-6°C / +4°C Groove width 0.50mm

 W75-24 Special H
-2°C / +4°C Groove width 0.75mm



★ ★ ★

Utilisé en Coupe du Monde
par de nombreuses équipes
nationales

Used in World Cup
by many national ski teams

★ ★ ★

× 56 ×



© AGENCE ZOOM



EST. 2018
VOLA
ROCKET
Team

D'année en année,
vous nous faites vibrer.
Suivez les aventures
de ces athlètes
hors du commun.
#rocketteam

FLY TO
SUCCESS



Gloves REF. 016016

Gants pour la préparation des skis.
Gloves for ski care.
Handschuhe für die Skipräparation.
Guanti per la preparazione degli sci.

Taille / Size = 9



Cleaner paper REF. 012032

Chiffon lustrant de finition. (x20) Permet de nettoyer les semelles après le brossage.
Cleaner paper for finishing. For cleaning skis of dust after brushing. (x20)
Reinigungsvlies für die Skipräparation. (x20)
Straccio splendido per pulire dopo la spazzolatura. (x20)



Antistatic rag REF. 012069

Rouleau de chiffon antistatique.
Antistatic rag roller.
Antistatischen Tuch Rolle.
Rotolo di panno antistatico.

L = 60m / l = 17cm



Glue REF. 015010

Colle pour fixation 100ml.
Binding glue. 100ml.
Bindungsleim. 100ml.
Colla di fissaggio. 100ml.



Decameter REF. S33010-20

Décamètre. 30m. Permet de tracer un slalom en suivant les distances réglementaires.
Decameter. 30m. To be use for adjusting a slalom course in order to respect international norms.
Dekameter. 30m.
Decametro. 30m.



Profile 2 REF. 015017

Demi-masque à double filtre de qualité supérieure. Livré avec 2 cartouches ABE1P3R. Pour se protéger lors de l'application de farts solides.
Half protective mask delivered with 2 cartridges of ABE1P3R quality. To protect yourself during the application of hot waxes.
Halbmaske Doppel-Filter-Qualität. Kommt mit 2 Patronen ABE1P3R. Zum Schutz bei der Anwendung von Wachsen.
Mezza maschera di qualità doppio filtro. Viene fornito con 2 cartucce ABE1P3R. Per protezione durante l'applicazione di sciolina.

REF. 015020
Jeu de deux cartouches de rechange.
Set of two replacement cartridges.
Set bestehend aus zwei Ersatzpatronen.
Set di due cartucce di ricambio.



T-Sept REF. 015018

Equipement de protection respiratoire à ventilation assistée. Livré avec 3 cartouches ABEK2P3. Pour se protéger lors de l'application de poudres à chaud.
Protective equipment delivered with 3 cartridges ABEK2P3. To protect yourself when applying powder with a wax iron.
Schutzrüstung PAPR. Kommt mit 3 Patronen ABEK2P3. Um sich zu schützen, wenn die Anwendung von Pulver mit eine Wachsbugeleise.
Attrezzature di protezione PAPR. Viene fornito con 3 cartucce ABEK2P3. Per proteggere se stessi quando l'applicazione di polvere a caldo.



Additif X14 REF. 013009

Additif pour eau de ponçage. Anti-oxydant, lubrifiant, dispersant, antigel. Dilution: 25 à 50%.
Additive for water of the pumicingmachine. Does not oxidize, lubricates, disperses, antifreeze. Dilution: from 25 to 50%.
Zusatz für das Wasser der Schleimmaschine. Oxydiert nicht, schmierend, streuend, Frostschutz. Verdünnung: von 25 bis 50%.
Aggiuntivo per acqua di sabbia. Anti-ossidando, lubrificando, disperdendo, anticongelante. Diluizione: da 25 a 50%.



Brake retainers

- 1 REF. 015007 / x200
- 2 REF. 015008 / x20

Sachet d'élastiques pour frein.
Brake retainers.
Packung Stopper-gummis.
Elastici in gomma.



PZD3 REF. 015015

Embout visseuse PZD3. 120mm.
Screwdriver PZD3. 120mm.
PZD3 Schraubendreher. 120mm.
Cacciavite PZD3. 120mm.



REF. 015013 / 3,5 * 7MM (JUNIOR SKIS)
REF. 015011 / 3,5 * 9MM
REF. 015012 / 4,1 * 9MM
REF. 015014 / 4,1 * 3,5 * 15MM (NORDIC SKIS)

Forets / Bit / Bohrer / Punteruolo

Snow marker REF. 017006

Coloneige. Disponible en 1L, 5L et 20L. Pour les pistes de vitesse ou tout type de tracé pour marquer des mouvements de terrain.
Snow marker. Available in 1L, 5L and 20L. Made for the downhill slopes or every kind of race in order to see the slope movements.
Schneecontrastmittel. 1L, 5L und 5L.
Gemacht für Abfahrt.
Colore. 1L, 5L e 20L. Venduto per le discipline di velocità e tutte le gare per vedere il rilievo.

De-freezing REF. 017003

Déglaçant mécanique. 5L. (peut être livré en 20L)
Facile d'utilisation, non toxique, non corrosif. Permet de débloquent toutes pièces bloquer par la glace telles que des glissières de téléskis, de cableries diverses, d'axes, articulations, paliers, roues, etc...
Mechanical de-freezing, 5L. (can be delivered in 20L bottle too) Easy to use, not toxic, does not oxidize. Allows to unlocked mechanical pieces of ski lift blocked by the ice such as wheels, axis, flexes ...
Machanisch Frostenferner. 5L. Einfach Bedienung, nicht toxisch, nicht lorrudierend. Wird der Frost lösen und die Bewegung der Teile wieder ermöglichen.
Einsatzbeispiele : Schilift Gleitfläche, Seilen, Achsen, Gelenke, Lager, Räder, usw.
Sghiacciatore meccanico. 5L. (E possibile di avere anche in 20L) Facile da utilizzare, non tossico, non corrosivo. Permette di sbloccare tutti i pezzi bloccati dal ghiaccio come giunti, cuscinetti, ruote, ecc.



REF. 015006 x1000
Chevilles plastiques.
Plastic hole plugs.
Plastikpfropfen für Bohrlöcher.
Tassello plastica.
Ø Dia = 4.5 mm



REF. 015005 x100
Insert plastique.
Plastic inserts.
Plastikdübel.
Inserto in plastica.
Ø Dia = 9 mm



REF. 015004 x100
Insert laiton.
Brass inserts.
Eindreh-Messingeesätze.
Inserto ottone.
Ø Dia = 8.5 mm

REF. 016015
Rouleaux de scotch VOLA.
VOLA Tape large.
Klebebänderolle Breit.
Nastro adesivo VOLA grande.



REF. 016014
Rouleaux de scotch VOLA fin.
VOLA Tape fine.
Klebebänderolle Fein.
Nastro adesivo VOLA fino.



REF. 016030
Scotch papier VOLA.
VOLA Tape paper.
Papier Klebebänderolle Breit.
Nastro adesivo VOLA.



REF. 016018 / MINI -20°C

Thermometer

Thermomètre / Hygromètre électronique. Livré avec sonde.
Thermometer / Hygrometer electronic. Delivered with a probe.
Thermometer / Feuchtigkeitsmesser elektronisch. Mit einer Sonde geliefert.
Termometro / Igrometro elettronico. Fornito con una sonda.

REF. 016019 / PRO



ACCESSORIES & MERCHANDISING



Trousse (wide) Kit (empty)
REF. 016057
Capacity 5L
Longueur/Length 27 Largeur/Width 12 Hauteur/Height 17cm



Petite mallette (vide) Small box (empty)
REF. 011069
Longueur/Length 27 Largeur/Width 23 Hauteur/Height 5cm



Mallette large (vide) Large box (empty)
REF. 011070
Longueur/Length 33 Largeur/Width 28 Hauteur/Height 12cm



Flag Black or White REF. 016043
Largeur/Width 70cm Hauteur/Height 3.5m



Roll Up REF. 016044
Largeur/Width 60cm Hauteur/Height 2m



Talkie-walkie holder REF. 016052



Apron REF. 016008



Key-holder REF. 016024



Tent REF. 016050
Largeur/Width 3m Longueur/Length 3m = 9m²



Banner REF. 016042
Largeur/Width 70 Longueur/Length 3m



Waist bag
1 Classic REF. 016027 Capacity 0,5L
2 Thermobelt REF. 016035 Capacity 1L



Straps
1 Alpine REF. 016006
2 Nordic REF. 016007
3 Nordic small REF. 016025



Cardboard Display REF. 016067
Largeur/Width 25 Longueur/Length 31 Hauteur/Height 52cm



Mini-Flag REF. 016061
Hauteur/Height 40cm

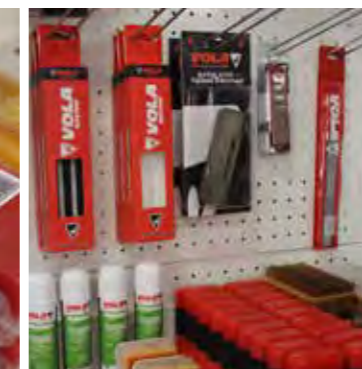

Metal Display REF. 016068
Largeur/Width 45 Longueur/Length 60 Hauteur/Height 2.10m



× 60 ×

× 61 ×

VOLA'S Distributors

ANDORRA

Oxigen Distribucions, s.l.
Ctra. Dels Cortals
Rcial. Cortals Baixos
AD200 Encamp
PRINCIPAT D'ANDORRA
✉ info@oxigen.ad
☎ +376 832560
☎ +376 343945

AUSTRIA

Life Sport Product's GmbH
Bahnhofstrasse 46
4810 GMUNDEN
✉ office@lsp-austria.at
☎ +43 76 12 70 777

BELGIQUE

Altitude 0
83, Chaussée de Waterloo
B-5002 NAMUR
✉ philippe.willems@altitudezero.be
☎ +32 81 73 76 43
☎ +32 495.500607

BULGARIA

Alpin Eood
Iztok str. Samokov 28-Z
Office 1
1113 SOFIA
✉ descentebg@gmail.com
☎ 00359 2 892 0202
☎ +359888614684

CANADA

Distribution Des Monts
162, Des Monts
ST SAUVEUR - QUÉBEC
j0r 1r5
✉ distributiondesmonts@gmail.com
☎ 450-227-0802

CHILE

Ski Nautica
Av Las Condes
7735 LAS CONDES
SANTIAGO
✉ abenvenutop@gmail.com
☎ +56 711 80 65

CHINA

Yueqing Wharton Int. Trading Co
Room 1103, NO.3, Chenmu Garden
District, YUEQING CITY
325600 ZHEJIANG
✉ andy@wharton-china.com
☎ +86 57761513377

CZECH REPUBLIC

Tomáš Tuček - STEATIT
Koutnikova 171/2
500 02 HRADEC KRALOVE
✉ info@volaracing.cz
☎ +420 606 929 043
☎ www.volaracing.cz

ESPANA

B&E Sports Division SL
Jordi Berini
✉ jberinim@gmail.com
☎ +34 609 750506
☎ www.besportsdivision.com

ESTONIA

Rendikeskus Oü
Jaanus Lõvi
Ranniku tee 1a,
Rannamõisa küla, 76906
✉ info@rendikeskus.ee
☎ 372 52 72 999

FINLANDE

Mankkaan Suksihuolto Oy
Sinikalliontie 4
02630 ESPOO
✉ info@mankkaansuksihuolto.com
☎ +358 50 304 3994

GERMANY

Reichmann & Sohn GmbH
Rudolf Diesel Strasse 6-8
89264 WEISSENHORN
✉ skiservice@reichmann.com
☎ 0049 73 09 875 75

FRANCE

Vola Racing / Factory
37, avenue de Saint-Martin
BP52, F-74190 PASSY
www.vola.fr
✉ vola@vola.fr
☎ +33 4 50 47 57 20

GREAT BRITAIN

Ski Bitz
8, Glenwood avenue
PO22 8BS WEST SUSSEX
✉ sales@ski-bitz.co.uk
☎ +44 779 525 5110

GREECE

Board Generation
4-6 Agg Sikelianou ST
11525 Neo Psyhiko ATHENS
✉ boardgen@otenet.gr
☎ +30 2106713879
☎ +30 2106777481
☎ www.boardgeneration.com

IRAN

Pamchal Sport
38th st., Asadabadi St,
14366 TEHRAN
✉ pamchalgroup@gmail.com
☎ 0098-21-88062663
☎ 0098-912-2769896
☎ +98 (0) 21 880 630 92

ITALIA

Confsport / Energiapura
Via Jolanda 59
36056 STROPPARI DI TEZZE SUL
BRENTA
✉ sales@energiapura.info
☎ +39 0424 539435

JAPON

Big M Snow Plan 18-6, 3-Chome,
Tsutsujigaoka, Inagawa-Cho,
Kawabe-Gun,
666-0245 Hyogo-Ken
✉ info@bigm-snowplan.com
☎ +81-72-746-3108

LATVIA

LTD JANIUS Gales Iela 27
LV2150 SIGULDA
✉ info@siguldasdzains.lv
☎ +371 679 70247
☎ www.volaracing.lv

LEBANON

Pic Blanc Sport
Zoghaib Building - Faraya Road
Po Box / Reyfoun 85
MAYROUBA (Kesrouane)
✉ anthony@picblancsports.com
☎ 961 9 330121

LIECHTENSTEIN

EDGE&BASE
Speedmax.li Est.
Palduinstrasse 52
9496 BALZERS
✉ info@edgeandbase.com
☎ +423 786 60 01
☎ www.edgeandbase.com

LITHUANIA

PROSPORT. LT
Vandziogalos str. 94
47467 KAUNAS
✉ info@prosport.lt
☎ +370 672 70159

NETHERLANDS

Vola Netherlands
Schipperlaan 3A
1906 BG LIMMEN
✉ info@volawax.nl
☎ 0031 (0)72 82 00 274
☎ www.volawax.nl

NEW ZEALAND

Bobo Products Ltd
5 Ross Street PO Box 43
Darfield 7510, Canterbury
✉ gerald@bobo.co.nz
☎ 03 317 9096
☎ 03 317 9095

NORWAY

Sport Alpin As
Gladvollveien 7G
1168 OSLO
✉ espen@sportalpin.no
☎ +47 905 011 16

POLAND

Malczewski Sport
Marcin Malczewski
ul.Oberconiuwka 26a
34-500 ZAKOPANE
✉ malczewskisport@gmail.com
☎ +48 609 603 034
☎ www.malczewskisport.pl

ROMANIA

Sc Alpin Ski Sport Arieseni Srl
Sat. Bubesti, Nr 88A,
com Arieseni, jud. Alba,
517040 ARIESENII 88A
✉ contactalpinski@yahoo.com
☎ +40 744 322 071
☎ +40 733 011 350

RUSSIA

DSS, Ltd.
Drezdenskaya Street,
case 8 / building 2,
194017 SAINT PETERSBURG
✉ e@dss-piter.ru / a@dss-piter.ru
☎ (812) - 293-06-77
☎ (812) - 293-06-78
☎ (812) - 293-11-37

SLOVAKIA

TT SPORT SK, s.r.o.
Trieda SNP 342/96
040 11 KOŠICE
✉ info@volaracing.sk
☎ +421 (0)949 138 648
☎ www.volaracing.sk

SOUTH-KOREA

Himazone
6-19 Gyeongchun-ro 227beon-gil
Guri-si Gyeonggi-do 11926
✉ kish@kotis.net
☎ +82 31 566 2336

SWEDEN

Wielsport Service AB
Gäddgardsgatan 4D
SE - 73246 ARBOGA
✉ info@wielsport.com
☎ +46 589 89700
☎ www.wielsport.com

SWITZERLAND

VOLA Racing.ch
c/o Nofival SA - Rue des Cèdres 10
CP 1163 - 1950 SION Valais
✉ sales@vola-racing.ch
☎ Suisse Romande : 032 534 87 79
☎ Deutsche Schweiz : 078 600 56 56
☎ www.vola-racing.ch

UKRAINE

Ecopolis West Ltd
Krasivskogo Str. 3-A
76018 Ivano - Frankivsk
✉ volaracingua@gmail.com
☎ +38 0342 55 28 40
☎ www.vola.com.ua

USA

Reliable Racing
643 Glen Street
Queensbury, NY 12804
✉ info@reliableracing.com
☎ +1 800 223 4448
☎ www.reliableracing.com

Shop Tek Inc. - DBA Ski Kare
5375 Orchard Street
80403 Golden Colorado
✉ gifford@ecentral.com
☎ +1 303 278 3828



@volaracing_sports

37, avenue de Saint-Martin / 74190 PASSY / FRANCE

☎ +33 (0)4 50 47 57 20 ☎ +33 (0)4 50 78 11 91 @ vola@vola.fr

☎ vola.fr